



XYLOPACK with screener and buffering storer



XYLOPACK - Pallet with net



XYLOPACK - Watertight plastic film



- Different rectangular jigs (moulds) to better fit the pallets : 80x120 cm, 100x100 cm, 100x120 cm, 120x120 cm or custom mold.
- Industrial machine with vibrating system for a better positioning of the log to gain a steady shape for palletizing and for a better filling optimization - RABAUD EXCLUSIVITY.
- Stretch and watertight plastic film (for dry wood) or net (green wood).
- Reel support with adjustable net tension system through a restrained roller.
- Hydraulic lifting system of the drum. Maximum height: 1.85 m (including the pallet).
- Machine managed by a module.
- The operator can access the parameters to modify the net tension, number of turns and the timing of drum lifting.
- Possibility to wrap down with the drum placed in high position.
- Radiocontrolled machine.
- Hydraulic unit with three-phase electric motor of 7,5 kW.
- Possibility of wrapping alone (banderoleuse).



XYLOPACK - Pallet with net

For more information, contact us on +33 (0)2 51 48 51 43



Specific conditions : Consult us

Technical characteristics

MODELS	Pallet mould											
	80x120			100x100			100x120			120x120		
	Logs lengths (cm)											
	25	33	50	25	33	50	25	33	50	25	33	50
Apparent wood volume (m ³)	1,60			1,60			2,00			2,40		
Stored wood volume (m ³)	1,75	1,60	1,20	1,75	1,60	1,20	2,20	2,00	1,5	2,64	2,40	1,80
Pallet useful height	1,85 m											

	Price	Reference
MODELS		
<i>Radio-controlled bagging machine ONLY : XYLOPACK</i> with log discharge chute	1 32215.00	79513A
<i>Set WITH radio-controlled bagging machine : XYLOPACK</i> <i>+ BUFFERING UNIT WITH LATH CONVEYOR</i> <i>+ 2M LONG SCREENER</i>	2 68070.00	79514A
<i>Set WITHOUT bagging machine</i> with footrest <i>BUFFERING UNIT WITH LATH CONVEYOR</i> <i>+ 2M LONG SCREENER</i> <i>+ CROSS CONVEYOR FOR XYLOPACK</i>	3 47185.00	70293A
<i>Set WITHOUT bagging machine</i> with footrest <i>BUFFERING UNIT WITH LATH CONVEYOR</i> <i>+ 4M LONG SCREENER</i> <i>+ CROSS CONVEYOR FOR XYLOPACK</i>	4 65610.00	70294A
 Specific conditions : Consult us		
PALLET MOULD > OBLIGATORY TO DETERMINE		
• Mould 80 x 120 cm	3400.00	79502A
• Mould 100 x 100 cm	3400.00	79512A
• Mould 100 x 120 cm	3650.00	79503A
• Mould 120 x 120 cm	3895.00	79504A
• Bespoke mould	Contact us	
OPTION		
Inspection hatch for lath inclined conveyer	2010.00	70298A
CONSOMMABLES		
Mesh coil	120.00	27D177
Stretch film coil 16 micrometer	125.00	27D190

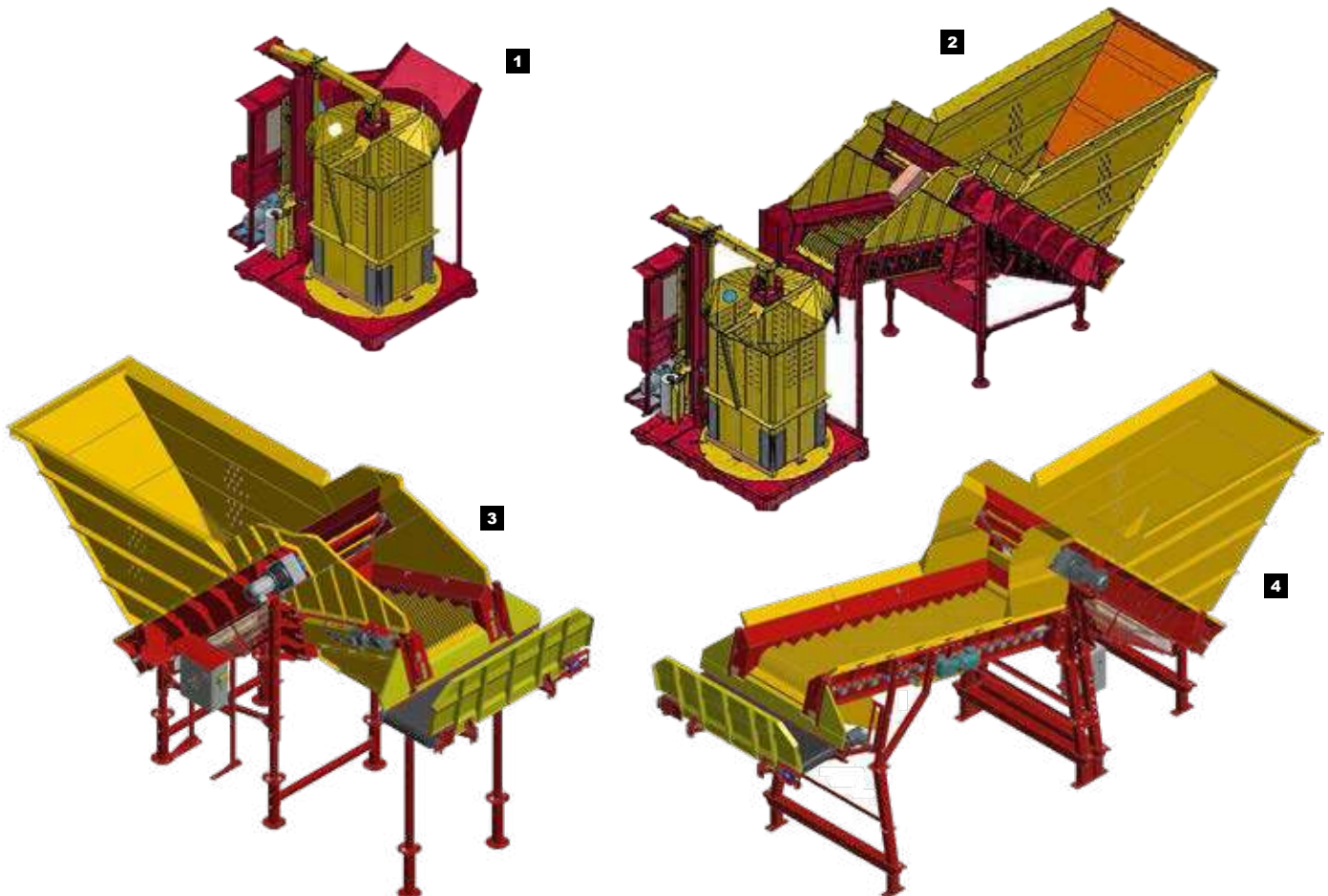



VIBRESCOPIC II BETWEEN WHEELS
+ Pre hole bar driver



VIBRESCOPIC II



VIBRESCOPIC II on mast PROVITIS



Rabaud
advantages

- Drives all posts in all types of grounds thanks to the exclusive power regulation of the striking controlled by the user
- Works in all positions: side shift, tilting and rotation.
- Excellent accuracy: the post is held during the work process.
- Small size during transport and operation (telescopic mast).
- Does not damage posts: power regulation.
- Manual controls by lever or radio remote control, or electro-hydraulic controls.
- Simple use : only one handle for lifting and lowering the hammer and for striking.
- Provides an excellent safety : the hammer vibrates only when the post is in direct contact with the striking head.
- Sturdy, forged, milled and processed striking head, Ø 150 mm, 5 years warranty.

Technical characteristics

MODEL	VIBRESCOPIC on stilt tractor
<i>Post length (maxi.)</i>	Depends on the carrier
<i>Striking head Ø</i>	150 mm
<i>Percussion hammer</i>	Adjustable from 0 to 950 strokes/min
<i>Hydraulic offset</i>	0.50 m for New Holland Braud - SB series only
<i>Inner/outer mast tilt</i>	20° / 25°

Standard equipment

- Vibrating hammer.
- Striking head Ø 150 mm.
- Oil filter (except PROVITIS).
- Flow divider 30 L/min.
- Anti-noise headset.

STRIKING HEAD **5 YEARS** WARRANTY



Special assembly : VIBRESCOPIC II STILTOR side shift of 0,75m right – left

		Price	Reference
MODELS			
VIBRESCOPIC II SIMPLE VITI BETWEEN TRACTOR WHEELS			
Adaptation between tractor wheels by the customer - without frame but with transversal support and tilting cylinder		12605.00	70331C
• 3-way valve with manual control			
• 3-way valve electrohydraulic control		14705.00	70332C
OPTIONS			
Hydraulic unit Driven by PTO 540 rpm - Pump 35 L/min. - 40 L tank (<i>with oil and shaft</i>)		Contact us	DIV703
Control Multifunction small joystick (<i>electro-hydraulic version only</i>)		2395.00	70377C
Pre-hole bar Ø 55 mm	alone - 1.30 m long - With storage holder	630.00	70322B
	with hydraulic extraction	manual control	2075.00
		electrohydraulic control	2120.00
Height extension of the mast for posts of 3.50 m high (<i>to order at purchase</i>)		720.00	70350C

		Price	Reference
MODELS			
VIBRESCOPIC II 15/35 to be adapted on carrier with MULTIPURPOSE MAST			
Hammer travel 500 mm - Pressure limiter 180 bar - 2 hydraulic hoses 1 m long (<i>without couplers</i>) - Storage stand		7775.00	70357C
• To adapt on PROVITIS - ATTENTION : delivered without the PROVITIS mast plate			
• To adapt on OTHER CARRIER		Contact us	DIV703

		Price	Reference
MODELS			
VIBRESCOPIC II to be adapted on straddle harvester with MULTIPURPOSE ARM			
Pressure limiter 175 bar		11225.00	70363C
• For arm PELLENC OPTIMUM (without electric tool recognition)			
<i>Delivered with 2 hydraulic hoses without couplers</i>			
• For arm PELLENC - Mast hydraulic tilting		11245.00	70327B
<i>Delivered with 4 hydraulic hoses without coupler</i>			
• For arm NEW HOLLAND VL and VM series		10260.00	70366B
<i>Delivered with 2 hydraulic hoses with New Holland couplers</i>			
OPTIONS			
Pre-hole bar Ø 55 mm with hydraulic extraction		1925.00	70329B

		Price	Reference
MODELS			
VIBRESCOPIC II STILTOR to adapt on straddle grape harvester or tool carrier SINGLE-ROWS (for your own adaptation)			
Hammer travel 1100 mm - Hydraulic tilting right/left +/- 20° - Hydraulic tilting front/rear 33°/32° or 44.5°/20°		11825.00	70318C
Ducted mast with a cylinder - 7 hydraulic hoses and 7 couplers			
VIBRESCOPIC II STILTOR to adapt on straddle grape harvester or tool carrier 2 ROWS (for your own adaptation)			
Hammer travel 1100 mm - Right/left translation 0,75 m - Hydraulic tilting front/rear 33°/32° or 44.5°/20°		Contact us	
Ducted mast with a dual-acting cylinder - 7 hydraulic hoses and 7 couplers			
OPTIONS			
3-way valve manual control		930.00	70387B
3-way valve with electrohydraulic control		Contact us	70389C
Multifunction mini lever		1955.00	70388C
Pre-hole bar Ø 30 mm with hydraulic extraction		1290.00	70319C

SELECT THE RIGHT COVER HEAD FOR METAL STAKES	
Cover head and support to select	See page 119



VIBRESCOPIC 150



VIBRESCOPIC 150 on bracket



VIBRESCOPIC 150



**Rabaud
advantages**

- Adaptation on all types of tractors.
- Own adaptation on your carrier possible.
- Drives all types of posts : iron, wood, etc. Ø 80 mm maximum.
- Its design allows to work between the vineyard rows. Ideal on flat land.
- Percussion up to 1000 strokes/min with only 15 L/min. oil needed.
- Folding mast and hammer allowing a total safety during transport.
- Side Storage and transport of posts (3-point hitch version).
- Easy use : Adjustable mechanical side offset with crank (1.62 m) and orientable telescopic mast 180°.
- Removable hammer for manual use.

Technical characteristics

MODEL	VIBRESCOPIC 150
<i>Posts length (max.)</i>	2,10 m
<i>Ø of posts (max.)</i>	80 mm
<i>Percussion hammer</i>	1000 strokes/min. (flow 15 L/min.)
<i>Maximum depth</i>	0,90 m
<i>Offset</i>	1,62 m
<i>Hydraulic needed</i>	Driven with one single-acting and return Flow 15 up to 25 L/min
<i>Dimensions (L x W x H)</i>	2,25 x 1,08 x 2,48 m
<i>Weight</i>	On tractor : 214 kg For special adaptation : 35 kg On bracket : 85 kg
<i>Pressure</i>	From 80 to 120 bar
<i>Coupling</i>	3-point N°1

Standard equipment

- Striking power 70 joule/stroke.
- 2 control handles.
- Anti-noise headset.
- Adjustable mast on 180° for VIBRESCOPIC 3-point hitch linkage.
- 2 hydraulic hoses, 8 m long, with 2 ½ male valve couplings (for personal adaptation).
- 2 male couplers ½ - 2 hoses 5 m long + 2 couplers (Bracket).



Post driver VIBRESCOPIC 150
for special adaptation

MODELS	Price	Reference
VIBRESCOPIC 150- for special adaptation	4050.00	70307C
VIBRESCOPIC 150- on bracket	4330.00	70396B
VIBRESCOPIC 150- 3-point hitch linkage	6360.00	70367B



- Post driver mounted on road trailer 130 km/h.
- Trailer weighs less than 750 kg. Conventional driving licence is required for moving.
- Driven by heat engine HONDA 22 HP.
- Post driver mounted on a 360° tool post, for side working.
- Telescopic arm enabling to drive posts up to 2,80 m and an lateral offset of 0,70 m.
- Percussion hammer mounted on a mast with anti-wear ertalon guides. The hammer is lowered by means of a cylinder to guide the post as it is driven into the ground, while exerting a supporting force by striking.
- Sturdy, forged, milled and processed striking head, Ø 150 mm, 5 years warranty.
- The hydraulic movement (rotation, offset, tilt and up/down of the striking head) are executed by radio-control.
- Automatic adjustment of tilting mast.
- Fully foldable machine for transport.

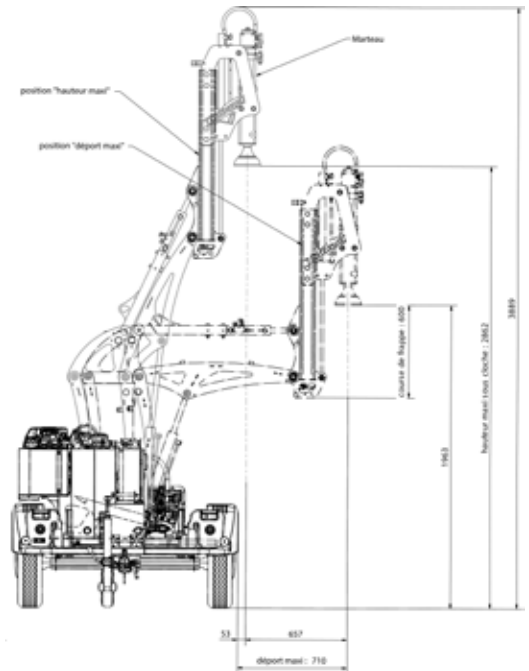

Pile shaping - Post driver
Auger - Unwinding machine

STRIKING HEAD **5** YEARS WARRANTY

	Price €	Reference
MODEL		
VIBRESCOPIC 15/35 M on road trailer	25895.00	70393C



FOR A PRICE OFFER OR DEMONSTRATION, CONSULT US



VIBRESCOPIC PRO 35/95 on telescopic



VIBRESCOPIC PRO 15/35 on mini-excavator



VIBRESCOPIC PRO 35/95



Rabaud advantages

- Adaptation on excavator, backhoe loader...
- Rabaud offers adaptation on automatic coupling hitch, for all brands.
- Drives posts of all sorts, in all grounds without adjustment.
- Excellent accuracy: the post is held during the work process.
- Easy to use
- Sturdy, forged, milled and processed striking head, Ø 150 mm, 5 years warranty.
- The machine does not damage the poles, since the power is regulated.

Standard equipment

- Vibrating hammer mounted on anti wear square profile.
- Striking head Ø 150 mm.
- Hammer support mast with hammer traction cylinder (390 kg support force at 100 bar).
- Oil filter for VIBRESCOPIC 35/95.
- 2 hydraulic hoses with couplers.
- Anti-noise headset.



Technical characteristics

MODELS	VIBRESCOPIC PRO 15/35	VIBRESCOPIC PRO 17/35	VIBRESCOPIC PRO 35/55	VIBRESCOPIC PRO 35/95
Post length (maxi.)	Depends on the carrier			
Striking head Ø	150 mm			
Percussion hammer	950 strokes/min.			1500 strokes/min
Square profile length	0,50 m		0,60 m	0,80 m
Hammer lowering	Traction cylinder			
Dimensions (L x W x H)	0,74 x 0,23 x 1,43 m	0,58 x 0,90 x 1,18 m	0,74 x 0,23 x 1,43 m	1,00 x 1,10 x 1,59 m
Weight	175 kg	200 kg	180 kg	335 kg
Power of vehicle	1.5 T to 3.5 T maxi. for excavator or telescopic	Excavator 1.7 T (2.5 T with hydraulic tilting) or front, compact or telescopic loader	3.5 T to 5.5 T maxi. for excavator or telescopic	Excavators from 3.5 T



Storage stand (standard equipment for 17/35 and 35/95)



RABAUD offers adaptations for all brands of quick-fit couplings.

RABAUD handles the entire order. Assembled and delivered to you = time saving

					Price	Reference
MODELS						
VIBRESCOPIC PRO 15/35 - For excavator from 1,5 to 3,5 T Traction cylinder - Flow divider 30 L/min. - 180 bar pressure limiter					6500.00	70339C
VIBRESCOPIC PRO 17/35 - For mini-excavator from 1,7 to 3,5 T Traction cylinder - Flow divider 30 L/min. - 180 bar pressure limiter - Storage stand					6770.00	70373C
VIBRESCOPIC PRO 35/55 - For excavator from 3,5 to 5,5 T Traction cylinder - Flow divider 30 L/min. - 180 bar pressure limiter					8475.00	70362C
VIBRESCOPIC PRO 35/95 - For excavator from 3,5 to 9,5 T Traction cylinder - Flow divider 48 L/min. - 180 bar pressure limiter - Storage stand					12095.00	70306C
COUPLING HITCH > OBLIGATORY TO DETERMINE for all models						
	PRO 15/35	PRO 17/35	PRO 35/55	PRO 35/95		
• Hitch for TELESCOPIIC or FRONT LOADER or SKID STEER		●		●	1230.00	77802A
• Dual coupling EURO / MX		●			1880.00	76424A
• Triple coupling EURO / MX / MANITOU		●			2385.00	76426A
• Excavator with automatic coupling hitch (except KLAC and VERACHTERTcouplings, consult us)	●	●	●	●	See page 230-233	
• STANDARD plate 8 holes without bolts for your own adaptation	●	●	●	●	85.00	70366703L
OPTIONS						
Storage support	●		●		415.00	70337C
Post lifting grab (a 2-dual-acting valve or a 6-way valve is needed)				●	1960.00	70364C
Hydraulic tilt +/- 20° (requires 2nd DE line or additional 6-way valve)		●			1215.00	70374C
				●	2135.00	70355C
6-way hydraulic valve + control box in cabin	+ winding electric cord 15 m		●	●	1115.00	70384C
	+ lead extension 12 m		●	●	840.00	70385C
Pre-hole bar Ø 55 mm - 1,30 m long		●		●	680.00	70303D
Pre-hole bar Ø 55 mm + hydraulic extraction				●	1970.00	70301C

The ● means compatibility of options with different models.
The ● indicates compatibility pending approval from RABAUD.

SELECT THE RIGHT COVER HEAD FOR METAL STAKES

Cover head and support to select



See page 119

✓ OPTIONS



Storage stand (standard equipment for 17/35 and 35/95)



Post lifting grab (2 dual-acting needed or 6-way hydraulic valve)

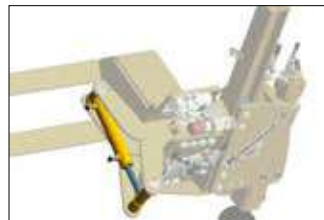

For hydraulic tilting option, see VIBRESCOPIC 17/35 model



6-way hydraulic valve + control box in cabin + winding electric cord 15m or lead extension 12m



Pre-hole bar alone Ø 55 mm 1,30 m long

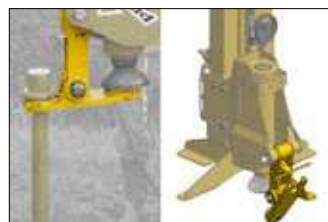

Pre-hole bar with hydraulic extraction



Permanent support for made-to-measure cover head



Adaptation for automatic coupling hitch all brands



VIBRESCOPIE PRO 18/40 on charger



VIBRESCOPIE PRO 18/40 with magazine coupling hitch



VIBRESCOPIE PRO 18/40 on excavator



Rabaud advantages

- Adaptation on mini-excavator, telescopic, front and compact loader.
- RABAUD offers a hitch according to your carrier
- New hammer with high striking frequency.
- Hammer mounted on shock-absorbing cushions to eliminate vibrations and reduce noise.
- Hydraulic tilting +/- 20° in option
- Lift/lower cylinder for a constant support on the post, to allow its holding.
- Percussion hammer mounted on a mast with anti-wear ertalon guides. The hammer is lowered by means of a cylinder to guide the post as it is driven into the ground, while exerting a supporting force by striking.
- Offset of the striking head to get a better view of the machine during the drive.
- Sturdy, forged, milled and processed striking head, Ø 150 mm, 5 years warranty.

NEW VIBRESCOPIE PRO 18/40

- 1700 strokes per minute
- Vibration and noise dampers

Technical characteristics

MODEL	VIBRESCOPIE PRO 18/40
<i>Posts length (max.)</i>	Depends on the carrier
<i>Striking head Ø</i>	150 mm
<i>Percussion hammer</i>	1700 strokes/min.
<i>Square profile length</i>	0,50 m
<i>Hammer lowering</i>	Traction cylinder
<i>Dimensions (L x W x H)</i>	0,57 x 0,94 x 1,17 m
<i>Weight (without linkage)</i>	220 kg
<i>Power of vehicle</i>	Excavator 1.8 to 4 T max. or front loader or telescopic loader

— Standard equipment —

- Hammer support mast with hammer traction cylinder (forced support 495 kg at 100 bar).
- 2 hydraulic hoses with couplers.
- Integrated storage stand.

STRIKING HEAD **5 YEARS** WARRANTY

		Price	Reference
MODELS			
VIBRESCOPIC PRO 18/40 Traction cylinder - Flow divider 35 L/min. - 180 bar pressure limiter - Storage stand		8150.00	70396C
COUPLING HITCH > OBLIGATORY TO DETERMINE for all models			
• Hitch for TELESCOPIC or FRONT LOADER or SKID STEER		1350.00	77802A
• Dual coupling EURO / MX		2065.00	76424A
• Triple coupling EURO / MX / MANITOU		2620.00	76426A
• Excavator with automatic coupling hitch		See page 230-233	
• STANDARD plate 8 holes without bolts for your own adaptation		94.50	70366703L
OPTIONS			
Hydraulic tilt +/- 20° (requires 2nd DE line or additional 6-way valve)		1215.00	70374C
6-way hydraulic valve + control box in cabin	+ winding electric cord 15 m	1115.00	70384C
	+ lead extension 12 m	840.00	70385C
Pre-hole bar Ø 55 mm - 1,30 m long		680.00	70303D

SELECT THE RIGHT COVER HEAD FOR METAL STAKES			
Permanent support for cover head, without cover head <i>Suitable with post drivers on mini-excavators / Not suitable with size 2 permanent cover head</i>			255.00 70397C
Made-to-measure cover head	Size 0	For circular posts Ø ≤ 80 or rectangular posts side size ≤ 50 x 60	790.00 703837
	Size 1	For circular posts Ø ≤ 150 or rectangular posts side size ≤ 100	1125.00 DIV703
	Size 2	For circular posts Ø ≤ 230 or rectangular posts side size ≤ 160	Contact us

✓ OPTIONS



Hydraulic tilting



Pre-hole bar alone Ø 55 mm
1,30 m long



6-way hydraulic valve
+ control box in cabin
+ winding electric cord 15m or lead extension 12m





TRH MANUAL



TRH MANUAL



TRH MANUAL with FENOX mooring



Rabaud
advantages

- Simple use with 2 persons with hydraulic motor.
- Works with the hydraulic of all carriers : minimum oil flow 20 L/min.
- Hydraulic valve to stop and reverse rotation.
- Accessories compatible with mooring brands : Ancrest, Fenox, etc.

Technical characteristics

MODEL	TRH MANUAL
<i>Drive</i>	Hydraulic via all carriers 42 mm hexagonal coupling
<i>Ø of augers</i>	100 up to 250 mm
<i>Oil flow minimum / maximum</i>	20 L/min / 50 L/min
<i>Pressure mini. / maxi.</i>	110 bar / 200 bar
<i>Weight (without auger)</i>	28 kg

Standard equipment

- Hydraulic valve, 2 hoses of 8 m long, 2 couplers (without auger - 250 mm max. Ø).
- 2-way hydraulic valve for stop and reverse rotation.



TRH MANUAL with FENOX mooring

MODEL	Price	Reference
TRH MANUAL for 2 people with hydraulic motor	1725.00	70694A
ACCESSORIES for anchoring - Hexagonal coupling 42 mm		
'ANCREST' mooring Ø 100 to 120 mm	275.00	70663B
'ANCREST' mooring Ø 150 mm	350.00	70664B
'FENOX' mooring Ø 120 mm	360.00	70662B
'LEBEC - AMARAGRI' mooring Ø 120 mm - Hole spacing 40 mm	315.00	70661B
Universal key for mooring welded on a rod (Maximum thickness 20 mm)	215.00	706523
AUGERS right pace with interchangeable blades length 1.10 m Hexagonal coupling 42 mm - Ø 100 to 250 mm		
Ø 100 mm - whorl 5 mm thick	450.00	70676B
Ø 120 mm - whorl 5 mm thick	485.00	70677B
Ø 150 mm - whorl 5 mm thick	500.00	70678B
Ø 200 mm - whorl 6 mm thick	590.00	70679B
Ø 250 mm - whorl 6 mm thick	685.00	70680B

Mooring
LEBEC



Mooring
AMARAGRI



Mooring
ANCREST



Mooring
FENOX





Hole digger MICROTRACTOR at work



Hole digger MICROTRACTOR at storage



Hole digger MICROTRACTOR at work



- Designed for micro-tractor up to 25 HP.
3-point linkage: N°1 and N°1N.
- Axial tubular frame.
- Safety gearbox : slipping clutch.
Angle gearbox : 1/5,22 ratio.
- 2 augers fitted with blades replaceable blades and points :
- 1 auger Ø 150 mm.
- 1 auger Ø 220 mm.
- Support stands.
- Delivered with augers and shaft.

Technical characteristics

MODEL	MICROTRACTOR
<i>Coupling</i>	3-point linkage n°1 and 1N
<i>Maximum tractor power</i>	25 HP
<i>Drive</i>	PTO 540 rpm
<i>Ø of augers</i>	150 mm and 220 mm
<i>Length of augers</i>	0,85 m
<i>Dimensions (L x W x H)</i>	1,57 x 1,58 x 1,35 m
<i>Weight</i>	127 kg
<i>Safety</i>	Slipping clutch

Standard equipment

- 2 augers fitted with blades, length 0,85 m, Ø 150 and 220 mm.
- 2 support stands.
- One transmission shaft with safety friction clutch.
Attention : rotates in only one direction.



Hole digger MICROTRACTOR at work

MODEL	Price	Reference
HOLE DIGGER FOR MICROTRACTOR - delivered with 2 blade augers, Ø 150 & 200 mm	2845.00	70677C
SPARE PARTS		
• Auger Ø 150 mm - Length 0.85 m	440.00	70679C
• Auger Ø 220 mm - Length 0.85 m	490.00	70680C



AXIAL II



SENIOR II



SENIOR II

- 2 models for tractors with more than 50 HP.
- Very wide choice of augers : more than 40 models from 100 to 600 mm Ø.
- Easy use: quick change of augers thanks to the hexagonal coupling - RABAUD EXCLUSIVITY.
- Excellent quality of the gear box allowing a maximum power for the hole digger.
- Rotation direction reverser device for the auger: allow releasing from stones/roots.
- Mechanical or hydraulic (option) offset to work all along vegetation.
- Secured gear box thanks to the automatic slipping clutch.
- New frame for quicker adaptation to your tractor.



Rabaud
advantages

Technical characteristics

MODELS	AXIAL II	SENIOR II
<i>Tractor power</i>	From 50 HP	
<i>Drive</i>	PTO 540 rpm with 1/6 gearbox	
<i>Coupling</i>	3-point N°2	
<i>Augers diameter</i>	100 mm to 600 mm	
<i>Offset range</i>	Non-removable	2,40 m
<i>Dimensions (L x W x H)</i>	2,27 x 1,16 x 1,30 m	
<i>Weight</i>	320 kg	327 kg
<i>Safety</i>	Slipping clutch	

Standard equipment

- 2 support stands.
- Transmission with a slipping clutch.
- Frame adapted to the recommended power of tractors.
- Reverse gear box - Manual control.

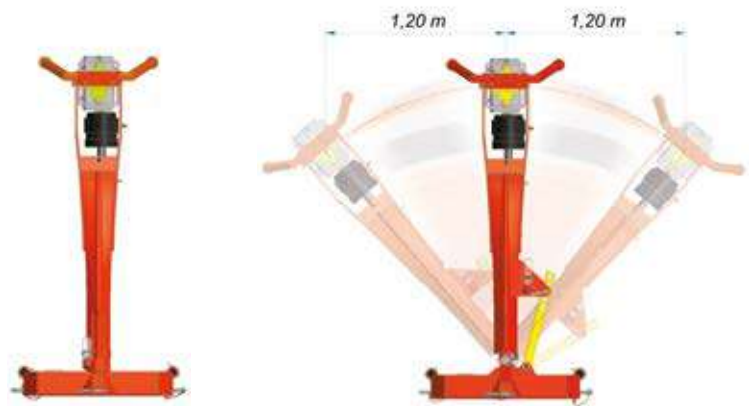

AXIALE II model

SENIOR II model

			Price	Reference
MODELS				
AXIAL II HOLE DIGGERS (without auger) With reverse gear box - Manual control			4950.00	70628D
OFFSET HOLE DIGGER SENIOR II (without auger) offset on left and right With reverse gear box - Manual control			5720.00	70630D
OPTIONS				
	AXIAL II	SENIOR II		
Hydraulic offset		●	375.00	70647B
Weight support (hydraulic offset obligatory for SENIOR II model)	●	●	270.00	70637B
Additional weight 25 kg (square of 350) without support (4 weights maxi.)	●	●	80.00	706400

Warning : the augers are delivered without axle nor pin
The ● means compatibility of options with different models.

AUGERS PAGES 140-141

✓ OPTIONS



Hydraulic offset (on SENIOR II model)

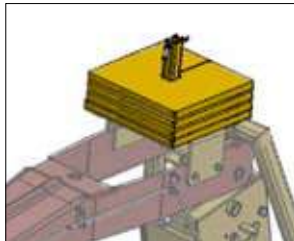

Additional weight





Auger MINI-JUNIOR



Auger MINI-JUNIOR with hydraulic offset



Auger JUNIOR



Rabaud advantages

- 2 models for tractors from 15 to 80 HP.
- Very wide choice of augers : more than 40 models from 100 to 600 mm Ø.
- Easy use: quick change of augers thanks to the hexagonal coupling - RABAUD EXCLUSIVITY.
- Excellent quality of the gear box allowing a maximum power for the hole digger.
- Rotation direction reverser device for the auger: allow releasing from stones/roots.
- Mechanical or hydraulic (option) offset to work all along vegetation.
- Secured gear box thanks to the automatic slipping clutch.
- New frame for quicker adaptation to your tractor.

Technical characteristics

MODELS	MINI-JUNIOR	JUNIOR
Tractor power	15 to 60 HP	30 to 80 HP
Drive	PTO 540 rpm with 1/6 gearbox	
Coupling	3-point N°1 and N°2	
Augers diameter	100 mm to 600 mm	
Offset range	1,50 m	2,00 m
Dimensions (L x W x H)	1,63 x 1,08 x 1,23 m	2,01 x 1,14 x 1,28 m
Weight	275 kg	290 kg
Safety	Slipping clutch	

Standard equipment

- 2 support stands.
- Transmission with a slipping clutch.
- Frame adapted to the recommended power of tractors.
- Reverse gear box - Manual control.

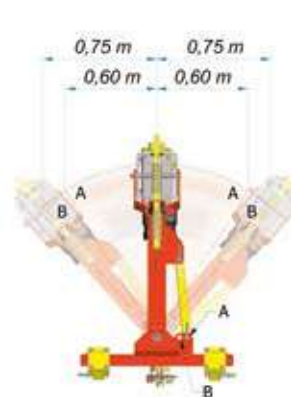

MINI-JUNIOR model

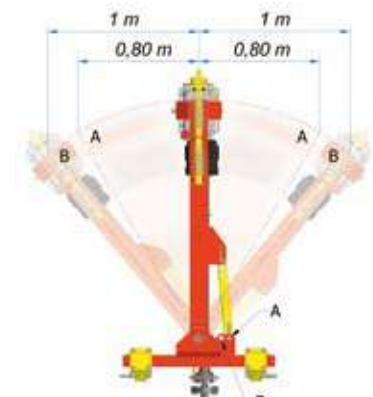

JUNIOR model

			Price	Reference
MODELS				
OFFSET HOLE DIGGER MINI JUNIOR (without auger) offset on left and right With reverse gear box - Manual control			4885.00	70682B
OFFSET HOLE DIGGER JUNIOR (without auger) offset on left and right With reverse gear box - Manual control			4890.00	70683A
OPTIONS	MINI-JUNIOR	JUNIOR		
Hydraulic offset	●	●	355.00	70646B
Hydraulic tilting +/- 25° with cylinder, 2 hoses, with 2 ½ male valve couplers (without valve)		●	980.00	70656B
Wire-protector for vineyard (only compatible with wine augers)	●	●	175.00	70668A
3-point linkage arm extension	●		265.00	70633B
ANCHORING ACCESSORIES - 80 mm hexagonal coupling				
'ANCREST' mooring Ø 100 to 120 mm (Picture page 132)	●	●	315.00	70669A
'ANCREST' mooring Ø 150 mm (Picture page 132)	●	●	400.00	70679A
'FENOX' mooring Ø 120 mm (Picture page 132)	●	●	470.00	70692A
'LEBEC - AMARAGRI' mooring Ø 120 mm (Picture page 132)	●	●	350.00	70610B
Universal key for mooring welded on a rod (Maximum thickness 20 mm)	●	●	225.00	706524

Warning : the augers are delivered without axle nor pin
 The ● means compatibility of options with different models.
 The ● indicates compatibility pending approval from RABAUD.

AUGERS PAGES 140-141

Pile shaping - Post driver
Auger - Unwinding machine

☑ OPTIONS



Hydraulic offset



Wire-protector for vineyard

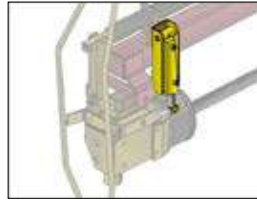

Hydraulic tilting



JUNIOR



Hole digger JUNIOR with wire-protector



Hydraulic hole digger on PELLENC



Hydraulic hole digger



Hydraulic hole digger on vineyard tractor



Rabaud advantages

- Adaptation on straddle tractors, tractor front 3-point linkage and other tool carriers.
- 90° or 180° orientation thanks to the hydraulic cylinder (max. reach 1,40 or 2,40 m).
- Hydraulic tilt as standard (for mooring lines, etc.).
- Designed for vineyard augers from Ø 400 mm to 600 mm.
- Adjustable parallelogram via cylinder.

Technical characteristics

MODELS	HOLE DIGGER NARROW	HOLE DIGGER STANDARD	HOLE DIGGER PELLENC
<i>Ø maximum (vineyard auger)</i>	600 mm		500 mm
<i>Auger's drive</i>	80 mm hexagon		
<i>Orientation</i>	90°	180°	84°
<i>Maximum reach</i>	1,41 m	2,40 m	1,74 m
<i>Coupling</i>	3-point N°1 and N°2		-
<i>Recommended pressure</i>	180 bar		
<i>Oil flow</i>	35 L/min. (mini.) - 50 L/min. (recommended) - 150 L/min. (max.)		
<i>Dimensions (L x W x H)</i>	1,45 x 0,60 x 0,90 m	1,45 x 0,90 x 0,90 m	2,00 x 1,42 x 1,64 m
<i>Weight</i>	236 kg	245 kg	-

Standard equipment

- Hole digger NARROW and STANDARD :
 - Left/right offset with gear-rack cylinder.
 - Lifting/lowering by dual-acting cylinder with parallelogram.
 - Tilting cylinder (setting mooring).*Length of hoses from mounting plate: 2.20 m for cylinders and 3 m for motor.*
- Hole digger PELLENC :
 - Hydraulic drive of hole digger engine with 2 couplers 1/2".
 - Lifting and lowering of the cylinder by single-acting with parallelogram.



Hydraulic hole digger with mooring



station trolley (for wide hole digger on straddle tractor)

	Price	Reference
MODELS		
NARROW HYDRAULIC HOLE DIGGER for straddle tractor 3-point hitch and other carrier Right/left offset 90° (1,41 m range) - without auger, without coupling	5825.00	70681E
WIDE HYDRAULIC HOLE DIGGER for straddle tractor 3-point hitch and other carrier Right/left offset 180° (2,40 m range) - without auger, without coupling	6075.00	70682E
COUPLING for STILT tractor > OBLIGATORY TO DETERMINE		
3-point linkage front or rear + 2 support stands	740.00	70613D
Coupling plate for individual adaptation	62.00	706481
OPTIONS		
Electro-hydraulic control by multipurpose mini joystick - 4 hydraulic functions with servo-controlled movements	3980.00	70690E
4-element hydraulic distributor with support and hydraulic hoses (for rear 3-point mounting)	855.00	70649E
Wire protector for vineyard (only compatible with wine augers)	200.00	70604E
Trolley for drop off and transportation	695.00	70640E

	Price	Reference
MODELS		
FRAME ONLY FOR STANDARD AXE without motor or auger 180° right and/or left rotation (range of 2,40 m) - Without auger, adaptation required	4699.00	70621F

	Price	Reference
MODELS		
HOLE DIGGER for PELLENC (Not compatible with OPTIMUM arm) Right and/or left orientation (range 1.74 m)	9045.00	70671B + 70667B
OPTIONS		
Wire-protector for vineyard	175.00	70668A
Auger extension - Length 0.30 m	415.00	70693B

VINEYARD AUGERS with right pace (80 mm hexagonal coupling) - 0.75 m length - Ø 300, 400, 500 or 600 mm	See pages 140-141
---	-------------------

	Price	Reference
ANCHORING ACCESSORIES - 80 mm hexagonal coupling		
'ANCREST' mooring Ø 100 to 120 mm (Picture page 132)	315.00	70669A
'ANCREST' mooring Ø 150 mm (Picture page 132)	399.00	70679A
'FENOX' mooring Ø 120 mm (Picture page 132)	460.00	70692A
'LEBEC - AMARAGRI' mooring Ø 120 mm (Picture page 132)	350.00	70610B
Universal key for mooring welded on a rod (Maximum thickness 20 mm)	225.00	706524

✓ OPTIONS



Multi-function mini lever



Wire-protector for vineyard



Trolley for drop off and transportation



Coupling plate for individual adaptation

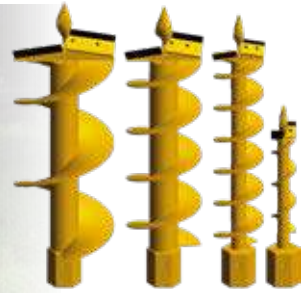

Augers fitted with blades for soft soils

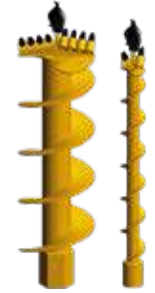

Augers fitted with carbide tungsten points for hard soils

	MINI-JUNIOR	JUNIOR	AXIAL II	SENIOR II	Price	Reference
AUGERS FITTED WITH BLADES - 0.75 m length - 80 mm hexagonal coupling - Augers right pace						
Ø 100 mm - whorl 5 mm thick	●				489.00	70694B
Ø 150 mm - whorl 5 mm thick	●				530.00	70696B
Ø 200 mm - whorl 6 mm thick	●				605.00	70697B
Ø 250 mm - whorl 6 mm thick	●				670.00	70698B
Ø 300 mm - whorl 6 mm thick	●				750.00	70699B
Ø 350 mm - whorl 8 mm thick	●				925.00	70601C
Ø 400 mm - whorl 8 mm thick	●				950.00	70602C
Ø 450 mm - whorl 8 mm thick	●				1215.00	70603C
Ø 500 mm - whorl 10 mm thick	●				1240.00	70604C
Ø 550 mm - whorl 10 mm thick	●				1345.00	70605C
Ø 600 mm - whorl 10 mm thick	●				1370.00	70606C
AUGERS FITTED WITH BLADES - 1.10 m length - 80 mm hexagonal coupling - Augers right pace						
Ø 100 mm - whorl 5 mm thick		●	●	●	550.00	70688B
Ø 150 mm - whorl 5 mm thick		●	●	●	600.00	70690B
Ø 200 mm - whorl 6 mm thick		●	●	●	685.00	70691B
Ø 250 mm - whorl 6 mm thick		●	●	●	755.00	70692B
Ø 300 mm - whorl 6 mm thick		●	●	●	835.00	70607C
Ø 350 mm - whorl 8 mm thick		●	●	●	970.00	70608C
Ø 400 mm - whorl 8 mm thick		●	●	●	1025.00	70609C
Ø 450 mm - whorl 8 mm thick		●	●	●	1300.00	70610C
Ø 500 mm - whorl 10 mm thick		●	●	●	1320.00	70611C
Ø 550 mm - whorl 10 mm thick		●	●	●	1445.00	70612C
Ø 600 mm - whorl 10 mm thick		●	●	●	1455.00	70613C
AUGERS FITTED WITH CARBIDE TEETH - Ø 19 mm - 1.10 m length - 80 mm hexagonal coupling - Augers right pace						
Ø 100 mm - whorl 5 mm thick - 2 teeth		●	●	●	645.00	70638C
Ø 150 mm - whorl 5 mm thick - 4 teeth		●	●	●	725.00	70639C
Ø 200 mm - whorl 6 mm thick - 4 teeth		●	●	●	840.00	70640C
Ø 250 mm - whorl 6 mm thick - 6 teeth		●	●	●	910.00	70641C
Ø 300 mm - whorl 6 mm thick - 8 teeth		●	●	●	1040.00	70642C
Ø 350 mm - whorl 8 mm thick - 8 teeth		●	●	●	1230.00	70643C
Ø 400 mm - whorl 8 mm thick - 10 teeth		●	●	●	1310.00	70644C
Ø 100 mm - whorl 8 mm thick - 12 teeth		●	●	●	1560.00	70645C
Ø 500 mm - whorl 10 mm thick - 12 teeth		●	●	●	1615.00	70646C
Ø 550 mm - whorl 10 mm thick - 14 teeth		●	●	●	1830.00	70647C
Ø 600 mm - whorl 10 mm thick - 18 teeth		●	●	●	1870.00	70648C

Warning : the augers are delivered without axle nor pin
The ● means compatibility of options with different models.

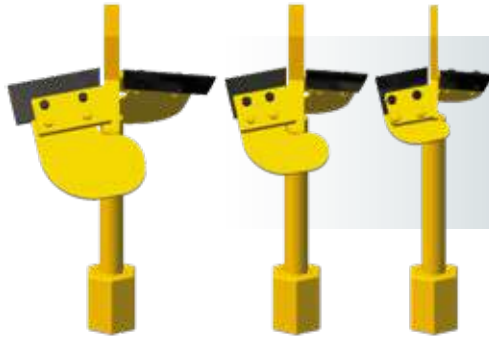

VINEYARD AUGERS
compatible with all models
Hexagonal coupling 80 mm - Length : 0.75 m

PLANTATION AUGERS
compatible with all models

- 1** FORESTRY "CAT TONGUE"
LENGTH : 1.10 M - Ø 60 MM
- 2** PLANTATION AUGER
LENGTH : 0.88 M - Ø 400, 500 AND 600 MM
- 3** LANDSCAPING MODE
LENGTH : 1.10 M - Ø 400 MM AND WHORL Ø 200 MM
- 4** FORESTRY MODEL
LENGTH : 1.10 M - Ø 550 MM

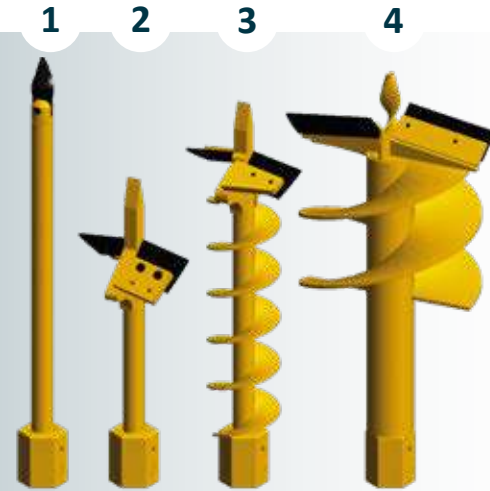

EXTENSION
compatible with all models
Hexagonal coupling 80 mm - Length: 0.30 m and 0.50 m

	MINI-JUNIOR	JUNIOR	AXIAL II	SENIOR II	Price	Reference
Vineyard augers with right pace						
Ø 300 mm	●	●	●	●	615.00	70689E
Ø 400 mm	●	●	●	●	625.00	70686B
Ø 500 mm	●	●	●	●	660.00	70687B
Ø 600 mm	●	●	●	●	680.00	70615C
Augers for plantation right pace - 80 mm hexagonal coupling						
1 Forestry model, length 1.10 m - Ø 60 mm		●	●	●	570.00	70616C
4 Forestry model, length 1.10 m - Ø 550 mm			●	●	1175.00	70617C
3 Landscaping, whorl Ø 200 mm, length 1.10 m - Ø 400 mm			●	●	985.00	70618C
2 Standard plantation auger - Length 0.88 m - Ø 400 mm	●	●	●	●	590.00	70655E
2 Standard plantation auger - Length 0.88 m - Ø 500 mm	●	●	●	●	625.00	70656E
2 Poplar tree plantation auger - Length 0.88 m - Ø 600 mm	●	●	●	●	645.00	70657E
Auger extensions (without whorl - 80 mm hexagonal coupling) - not compatible with Ø 100 mm augers						
Auger extension - Length 0.30 m	●	●	●	●	456.00	70693B
Auger extension - Length 0.50 m		●	●	●	510.00	70624C

Warning : the augers are delivered without axle nor pin
The ● means compatibility of options with different models.
The ● indicates compatibility pending approval from RABAUD.

	Price	Reference
SPARE PARTS FOR ALL AUGERS		
Augers knife right pace (a pair)		
Ø 100 mm	20.60	706067001
Ø 120 mm	21.70	706068001
Ø 150 mm	21.70	706042001
Ø 200 mm	21.70	706043001
Ø 250 mm	24.00	706044001
Ø 300 mm	26.40	706045001
Ø 350 mm	28.60	706046001
Ø 400 mm	30.90	706047001
Ø 450 mm	33.10	706048001
Ø 500 mm	36.60	706049001
Ø 550 mm	40.00	706050001
Ø 600 mm	43.30	706051001
Ø 800 mm	54.80	706069001
Knives for vineyard augers (unit)		
Ø 400 mm	57.00	706290001
Ø 500 mm	69.70	706291001
Ø 600 mm	85.50	706292001
Point for augers with blade		
Ø 100 - 120 - 150 mm	54.80	706271001
Ø 200 - 250 mm	71.80	706274001
Ø 300 - 350 mm	75.20	706276001
Ø 400 - 800 mm	81.00	706280001
Point for auger with teeth (all diameter)		
All diameters	97.20	31A012
Tungsten carbide teeth		
Ø 19 mm	14.90	24A024
Ø 25 mm	18.30	24A057
Tungsten carbide tooth support Ø 19 mm (to be welded to the spindle)	35.40	24A023
Tungsten carbide tooth support Ø 25 mm (to be welded to the spindle)	42.20	24A058
Hexagons		
Female Ø 80 mm - to weld on auger	239.00	931A06
Female Ø 42 mm - to weld on auger	124.30	931A05
Male reverse gearbox output	223.00	706380
Male standard gearbox output	223.00	706379
Male (no machining)	98.20	706097002
Male hexagon intermediary fixing with plate 6 holes	300.00	706100
Female hexagon intermediary fixing with plate 6 holes	357.00	706101
Plate 4 holes (Bouyer)	142.60	706314
Squares		
Female 100 x 100 mm – to weld on auger	670.00	706190
Female 130 x 130 mm – to weld on auger	1010.00	706378
Male 100 x 100 mm	468.00	706392003
Male 130 x 130 mm	635.00	706362002



Auger knife



welded tip



Replaceable point



Teeth and teeth support



Female hexagon



Female square

HYDRAULIC HOLE DIGGER COMPLETE COMPOSITION

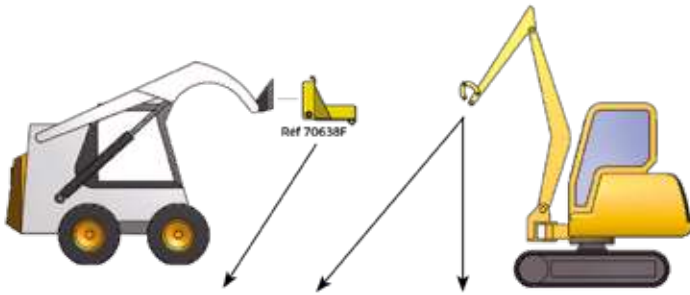

HOLE DIGGERS WITH GEARED MOTOR TMR

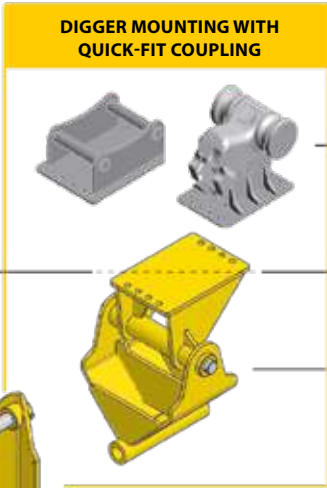
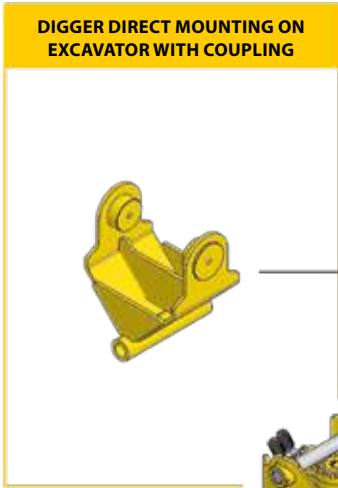

ADAPTATION FOR QUICK-FIT COUPLING
 BRAND TO DETERMINE
 (PAGES 230-233)

SIMPLE SUSPENSION HITCH DIRECTLY ON THE ARM

SUSPENSION HITCH DIRECTLY ON THE ARM

Suspension hitch directly on the arm or with a plate to screw on your quick-fit coupling

HYDRAULIC HOLE DIGGER WITH MOTOR PROTECTED BY SOLID FRAME

HEXAGONAL OR SQUARED
 to plug for easy auger mounting and changing

EXTENSION
 (in option)

AUGERS with carbide teeth or blades, high width whorl for a better soil extraction

TEETH AND TOOTH SUPPORT
 tungsten carbid point, anchored within the peak's mass.



Anti-sway **DEVICE**

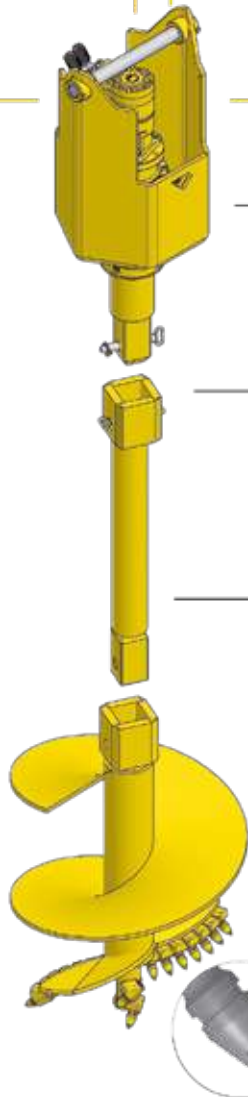



TRH 252 on mini excavator



TRH 406



TRH 508 on telescopic handler

5
YEARS
WARRANTY

+ Rabaud advantages

- 3 models adaptable on hydraulic carriers such as mini-excavator, compact loader, telescopic handler...
- No drainage = quick and less expensive mounting.
- A very wide choice of augers: more than 30 models from 100 to 600 mm
- Easy quick mounting / change of augers thanks to the hexagonal coupling
- Fit all types of carriers thanks to all existing quick couplings.
- Options : Extensions from 0.30 m to 2 m / Anti-sway system / ditching augers / Storage stand for 4 or 7 accessories.

— Standard equipment

- TRH 252 : 1 hydraulic motor - 2 hydraulic hoses 1.50 m long without couplers.
- TRH 406 and 508 : 1 hydraulic motor - 2 hydraulic hoses 2.00 m long without couplers (special models for telescopic loaders).

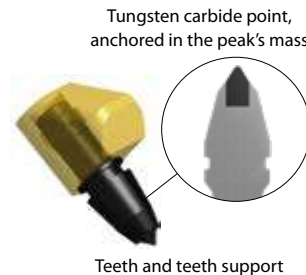

Teeth and teeth support



Replaceable auger's point in high resistance steel

Technical characteristics

MODELS	TRH 252	TRH 406	TRH 508
Coupling	Mini excavator from 0.8 to 2.2 T	Mini excavator from 3.5 to 6 T or telescopic loader	Mini excavator from 3.5 to 8 T or telescopic loader
Max. recommended auger Ø (hard soils / soft soils)	200 / 300 mm	400 / 500 mm	500 / 600 mm
Auger's drive	Hexagon 42 mm	Hexagon 80 mm	
Oil flow recommended (max.)	25 L/min (60 L/min)	50 l/min (200 l/min)	80 l/min (200 l/min)
Pressure mini. / maxi.	120 - 240 bar	150 - 180 bar	
Rotation speed with recommended flow	75 rpm	100 rpm	
Drainage	No		
Weight without hitch	26 kg	96 kg	99 kg

5 YEARS WARRANTY HOLE DIGGER



Auger with carbide teeth



Auger with strengthened whorl



Auger special for DITCHING for the cleaning of a ditch



Auger with widening system



TMR 605 on mini excavator

5 YEARS WARRANTY
HOLE DIGGER



TMR 1120



TMR 1325

5 YEARS WARRANTY

- A full range of 7 models to be adapted on backhoe loaders & excavators from 2 to 30 T.
- **Machines fitted with a high-torque geared motor** for driving augers up to 1500 mm Ø.
- No drainage = quick and less expensive mounting.
- A very wide choice of augers: more than 25 models from 100 to 1500 mm quickly interchangeable.
- Easy quick mounting / change of augers thanks to the hexagonal or squared fastening device.
- Fit all types of carriers thanks to all existing quick couplings.

Rabaud advantages

**HOLE DIGGERS WITH GEARED MOTOR
EVEN MORE TORQUE
FOR AUGERS UP TO
1500 MM Ø**

Pile shaping - Post driver
Auger - Unwinding machine

Standard equipment

- 1 geared motor on TMR 403 and TMR 605.
1 geared motor with pressure limiter on TMR 710 and TMR 1530.
- TMR 403 and TMR 605 : 2 hydraulic hoses 2 m long, 5/8" (without couplers).
- TMR 710, 914 and 1120 : 2 hydraulic hoses 2.50 m long, 3/4" (without couplers).
- TMR 1325 and 1530 : 2 hydraulic hoses 3 m long, 3/4" (without couplers).



POSSIBLE ADAPTATION TO FIT QUICK-FIT COUPLINGS PROCESSED AT OUR FACTORY

Technical characteristics

MODELS	TMR 403	TMR 605	TMR 710	TMR 914	TMR 1120	TMR 1325	TMR 1530
Coupling	Mini-excavator from 2 to 3T	Mini-excavator from 2,5 to 5 T	Mini-excavator from 5 to 10T	Mini-excavator from 8 to 14 T	Excavator from 14 to 20T	Excavator from 18 to 25 T	Excavator from 22 to 30 T
Max. recommended auger Ø (soft soils / hard soils)	300 / 400 mm	500 / 600 mm	600 / 700 mm	800 / 900 mm	1000 / 1100 mm	1200 / 1300 mm	1300 / 1500 mm
Auger's drive	Hexagon 80 mm				Square 100 mm		
Oil flow recommended	30 L/min	40 L/min	45 L/min	70 L/min	60 L/min	80 L/min	
Max. oil flow	70 L/min	60 L/min	75 L/min		114 L/min		
Pressure mini. / maxi.	180 - 200 bar	190 - 240 bar	200 - 280 bar	220 - 280 bar		240 - 280 bar	
Max. torque *	1894 Nm	4733 Nm	6842 Nm	16441 Nm	21602 Nm	28785 Nm	35754 Nm
Rotation speed with recommended flow	60 rpm	32 rpm	22 rpm	24 rpm	16 rpm	20 rpm	16 rpm
Drainage	No						
Weight without hitch	69 kg	70 kg	148 kg	215 kg	299 kg	352 kg	430 kg

* Rotation speed depends on oil flow

											Price	Reference			
MODELS (WITHOUT AUGER AND WITHOUT SUSPENSION HITCH)															
• TRH 252 (for excavator from 0.8 to 2.2 T / Ø auger 300 mm max., 42 mm hexagonal coupling)											1460.00	70641D			
• TRH 406 (for telescopic or excavator from 3.5 to 6 T / Ø auger 500 mm max., 80 mm hexagonal coupling)											3090.00	70623F			
• TRH 508 (for telescopic or excavator from 3.5 to 8 T / Ø auger 600 mm max., 80 mm hexagonal coupling)											3270.00	70624F			
MODELS (WITHOUT AUGER AND WITHOUT SUSPENSION HITCH)															
• TMR 403 (for excavator from 2 T to 3 T / Ø auger 400 mm max., 80 mm hexagonal coupling)											2225.00	70601F			
• TMR 605 (for excavator from 2,5 T to 5 T / Ø auger 600 mm max., 80 mm hexagonal coupling)											2540.00	70693E			
• TMR 710 (for excavator from 5 T to 10 T / Ø auger 700 mm max., 80 mm hexagonal coupling)											3890.00	70626F			
• TMR 914 (for excavator from 8 T to 14 T / Ø auger 900 mm max., 80 mm hexagonal coupling)											4770.00	70627F			
• TMR 1120 (for excavator from 14 T to 20 T / Ø auger 1100 mm max., 80 mm hexagonal coupling)											6570.00	70628F			
• TMR 1325 (for excavator from 18 T to 25 T / Ø auger 1300 mm max., 100 mm square coupling)											8360.00	70696D			
• TMR 1530 (for excavator from 22 T to 30 T / Ø auger 1500 mm max., 100 mm square coupling)											10925.00	70697D			
SUSPENSION HITCH > OBLIGATORY TO DETERMINE				TRH 252	TRH 406	TRH 508	TMR 403	TMR 605	TMR 710	TMR 914	TMR 1120	TMR 1325	TMR 1530	Price	Reference
Truck Crane coupling hitch	Arm width to be defined	●	●	●	●	●								330.00	70642D
	Arm width 50 to 120 mm							●						315.00	70626B
	Arm width 121 to 200 mm							●						385.00	70627B
	Arm width 201 mm up and more							●						545.00	70628B
	Arm width 200 mm up and more									●	●			695.00	70675D
Truck Crane coupling hitch											●	●		780.00	70653B
Truck Crane coupling hitch		●			●	●								280.00	70610F
Suspension hitch with plate to screw on quick-fit coupling (without quick-fit coupling to determine pages 230-233)		●	●	●	●	●			●	●				300.00	76905A
									●					685.00	76974A
											●			685.00	76902A
												●	●	890.00	76903A
Standard plate 8 holes	●	●	●	●	●	●	●	●	●	●	●	●	85.00	70366703L	
For carriers with carriage: skid-steer loader, front loader, telescopic handler, etc. with direct coupling hitch included.		●	●	●	●	●								825.00	70638F
								●						860.00	70639F

	TRH 252	TRH 406	TRH 508	TMR 403	TMR 605	TMR 710	TMR 914	TMR 1120	TMR 1325	TMR 1530	Price	Reference
AUGERS -Carbide teeth Ø 19 mm - hexagonal coupling 42 mm - length 1.10 m - right pace												
Ø 100 mm - whorl 4 mm thick - 2 teeth	●										505.00	70611F
Ø 150 mm - whorl 4 mm thick - 4 teeth	●										580.00	70612F
Ø 200 mm - whorl 4 mm thick - 4 teeth	●										675.00	70613F
Ø 250 mm - whorl 4 mm thick - 6 teeth	●										745.00	70614F
Ø 300 mm - whorl 4 mm thick - 8 teeth	●										825.00	70615F
AUGERS - Carbide teeth Ø 19 mm - hexagonal coupling 80 mm - length 1.10 m - right pace												
Ø 100 mm - whorl 4 mm thick - 2 teeth		●	●	●	●						515.00	70616F
Ø 150 mm - whorl 4 mm thick - 4 teeth		●	●	●	●						590.00	70617F
Ø 200 mm - whorl 4 mm thick - 4 teeth		●	●	●	●						685.00	70618F
Ø 250 mm - whorl 4 mm thick - 6 teeth		●	●	●	●						755.00	70619F
Ø 300 mm - whorl 4 mm thick - 8 teeth		●	●	●	●						840.00	70620F

The ● means compatibility of options with different models.
The ● indicates compatibility pending approval from RABAUD.



	TRH 252	TRH 406	TRH 508	TMR 403	TMR 605	TMR 710	TMR 914	TMR 1120	TMR 1325	TMR 1530	Price	Reference
STANDARD AUGERS - Carbide teeth Ø 19 mm - hexagonal coupling 42 mm - length 1.10 m - right pace												
Ø 100 mm - whorl 5 mm thick - 2 teeth	●										630.00	70605E
Ø 150 mm - whorl 5 mm thick - 4 teeth	●										725.00	70606E
Ø 200 mm - whorl 6 mm thick - 4 teeth	●										845.00	70607E
Ø 250 mm - whorl 6 mm thick - 6 teeth	●										925.00	70608E
Ø 300 mm - whorl 6 mm thick - 8 teeth	●										1020.00	70647E
VINEYARDS AUGERS Ø 300 mm - Hexagonal coupling 42 mm - Length 0,75 m												
Length 0,75 m	●										560.00	70652E
STANDARD AUGERS - Carbide teeth Ø 19 mm - hexagonal coupling 80 mm - length 1.10 m - right pace												
Ø 100 mm - whorl 5 mm thick - 2 teeth		●	●	●	●						645.00	70638C
Ø 150 mm - whorl 5 mm thick - 4 teeth		●	●	●	●						725.00	70639C
Ø 200 mm - whorl 6 mm thick - 4 teeth		●	●	●	●						840.00	70640C
Ø 250 mm - whorl 6 mm thick - 6 teeth		●	●	●	●						910.00	70641C
Ø 300 mm - whorl 6 mm thick - 8 teeth		●	●	●	●	●	●	●			1040.00	70642C
Ø 350 mm - whorl 8 mm thick - 8 teeth		●	●	●	●	●	●	●			1230.00	70643C
Ø 400 mm - whorl 8 mm thick - 10 teeth		●	●	●	●	●	●	●			1310.00	70644C
Ø 100 mm - whorl 8 mm thick - 12 teeth	●	●		●	●	●	●	●			1560.00	70645C
Ø 500 mm - whorl 10 mm thick - 12 teeth	●	●		●	●	●	●	●			1615.00	70646C
Ø 550 mm - whorl 10 mm thick - 14 teeth			●	●	●	●	●	●			1830.00	70647C
Ø 600 mm - whorl 10 mm thick - 18 teeth			●		●	●	●	●			1870.00	70648C
Ø 700 mm - whorl 10 mm thick - 20 teeth						●	●	●			2735.00	70673D
Ø 800 mm - whorl 10 mm thick - 22 teeth							●	●			3215.00	70654C
Ø 900 mm - whorl 10 mm thick - 24 teeth								●	●		3530.00	70622E
Ø 1000 mm - whorl 10 mm thick - 28 teeth*								●	●	●	3805.00	70623E
AUGERS WITH STRENGTHENED WHORL with driver - Carbide teeth Ø 19 mm - hexagonal coupling 80 mm - length 1.10 m - right pace												
Ø 250 mm - whorl 10 mm thick - 6 teeth		●	●	●	●	●	●	●			1540.00	70649C
Ø 300 mm - whorl 10 mm thick - 8 teeth		●	●	●	●	●	●	●			1730.00	70626E
Ø 350 mm - whorl 12 mm thick - 10 teeth		●	●	●	●	●	●	●			1830.00	70608F
Ø 400 mm - whorl 12 mm thick - 12 teeth		●	●	●	●	●	●	●			1920.00	70650C
Ø 500 mm - whorl 15 mm thick - 14 teeth			●	●	●	●	●	●			2455.00	70638E
Ø 600 mm - whorl 15 mm thick - 16 teeth					●	●	●	●			2935.00	70655C
Ø 700 mm - whorl 15 mm thick - 18 teeth						●	●	●			3475.00	70674D
Ø 800 mm - whorl 15 mm thick - 22 teeth							●	●			4015.00	70656C
Ø 900 mm - whorl 15 mm thick - 24 teeth								●	●		4850.00	70613E
Ø 1000 mm - whorl 15 mm thick - 28 teeth*								●	●	●	5425.00	70614E
Ø 1100 mm - whorl 15 mm thick - 30 teeth*								●	●	●	5925.00	70615E
AUGERS WITH STRENGTHENED WHORL with driver - Carbide teeth Ø 25 mm - square coupling 100 mm - length 1.10 m - right pace												
Ø 400 mm - whorl 12 mm thick - 10 teeth									●	●	2565.00	70662C
Ø 500 mm - whorl 15 mm thick - 12 teeth									●	●	3260.00	70636E
Ø 600 mm - whorl 15 mm thick - 14 teeth									●	●	3925.00	70663C
Ø 700 mm - whorl 15 mm thick - 16 teeth									●	●	4525.00	70637E
Ø 800 mm - whorl 15 mm thick - 18 teeth									●	●	5120.00	70664C
Ø 900 mm - whorl 15 mm thick - 20 teeth									●	●	6065.00	70665C
Ø 1000 mm - whorl 15 mm thick - 22 teeth									●	●	7340.00	70666C
Ø 1100 mm - whorl 15 mm thick - 24 teeth									●	●	7920.00	70619E
Ø 1200 mm - whorl 15 mm thick - 26 teeth									●	●	8505.00	70667C
Ø 1400 mm - whorl 15 mm thick - 30 teeth									●	●	9670.00	70624E
Ø 1500 mm - whorl 15 mm thick - 32 teeth									●	●	10260.00	70625E
* ADAPTATION												
Square male socket of 100x100 with an hexagonal female plug of 80									●		645.00	70621E
Square female socket of 100x100 with an hexagonal male plug of 80									●	●	645.00	70620E

The ● means compatibility of options with different models.
The ● indicates compatibility pending approval from RABAUD.

	TRH 252	TRH 406	TRH 508	TMR 403	TMR 605	TMR 710	TMR 914	TMR 1120	TMR 1325	TMR 1530	Price	Reference	
AUGER EXTENSIONS - Hexagonal coupling 42 mm - Without whorl													
Auger extension - Length 0.50 m	•										434.00	70644E	
AUGER EXTENSIONS - Hexagonal coupling 80 mm - Without whorl													
Auger extension - Length 0.30 m		•	•	•	•	•	•	•			456.00	70693B	
Auger extension - Length 0.50 m		•	•	•	•	•	•	•			510.00	70624C	
Auger extension - Length 1.00 m		•	•	•	•	•	•	•			660.00	70625C	
Auger extension - Length 2.00 m		•	•	•	•	•	•	•			825.00	70626C	
AUGER EXTENSIONS - 100mm square coupling - Without whorl													
Auger extension - Length 1.00 m									•	•	1510.00	70668C	
Auger extension - Length 2.00 m									•	•	1815.00	70669C	
AUGERS SPECIAL FOR DITCHING - Hexagonal coupling 80 mm - Length 1.10 m - right pace													
Ø 280 mm		•	•	•	•	•	•	•			1005.00	70630E	
Ø 380 mm		•	•	•	•	•	•	•			1105.00	70677D	
Ø 480 mm		•	•		•	•	•	•			1190.00	70678D	
Ø 580 mm			•		•	•	•	•			1370.00	70620D	
Ø 680 mm						•	•	•			1515.00	70684D	
Ø 780 mm						•	•	•			1640.00	70621D	
Ø 880 mm							•	•			1700.00	70616E	
Ø 980 mm								•	•	•	1760.00	70617E	
AUGERS SPECIAL FOR DITCHING - 100 mm square coupling - Length 1.10 m - right pace													
Ø 380 mm									•	•	1335.00	70631E	
Ø 480 mm									•	•	1440.00	70632E	
Ø 580 mm									•	•	1595.00	70603D	
Ø 680 mm									•	•	1760.00	70633E	
Ø 780 mm									•	•	1860.00	70604D	
Ø 880 mm									•	•	1990.00	70687E	
Ø 980 mm									•	•	2100.00	70605D	
Ø 1080 mm									•	•	2185.00	70639E	
Ø 1180 mm									•	•	2280.00	70606D	
Ø 1280 mm									•	•	2570.00	70634E	
Ø 1380 mm										•	2785.00	70642E	
Widening augers system													
100 mm (+ 200 mm on Ø), teeth Ø 25 mm, a pair									•	•	•	1160.00	70637D
OPTIONS													
Anti-swinging device during the transportation (only with bolt-on coupling)		•	•	•	•						298.00	70654Z	
Tilt meter with indicator inside cabin		•	•	•	•	•	•	•	•	•	1620.00	99158A	

	Price	Reference
MODELS		
STORAGE STAND FOR HOLE DIGGER + ACCESSORIES : TRH & TMR 403, 605 • For 1 hole digger (with or without hitch) + 4 accessories (upon request)	620.00	70610E
• For 1 hole digger (with or without hitch) + 7 accessories (upon request)	980.00	70611E
STORAGE STAND FOR HOLE DIGGER + ACCESSORIES TMR 710 & TMR 914 • For 1 hole digger (with or without hitch) + 7 accessories (upon request)	1090.00	70609F
STORAGE STAND FOR HOLE DIGGER + ACCESSORIES : TMR 1120 to TMR 1530 • For 1 hole digger (with or without hitch) + from 4 to 8 accessories according to the augers diameter	6155.00	70629E

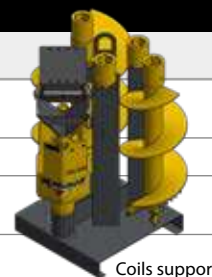

Coils support

- Hydraulic hole digger for big excavators from 25 to 50 Ton.
- Fit all types of carriers thanks to all existing quick couplings.
- Compatible with Biogas use with drilling augers.
- Drilling auger : length 1.10 m Ø 600 mm with reinforced coils 20 mm thick in 400 HB steel. Cutting edges and bevelled centring plate.
- Easy installation of the spindles thanks to the square attachment: 130 mm.
- Possibility of installing 7 extensions, for a drilling depth of 30 metres.
- Extension: length 4.40 m Ø 600 mm with reinforced coils, thickness 20 mm.
- Quality direct-drive hydraulic motor for maximum auger power (no gearbox, no maintenance).



Technical characteristics

MODEL	TRH 1550
Excavator operational weight	25 to 50 Tons
Max. auger Ø	1500 mm
Auger's drive	Square 130 mm
Oil flow recommended	200 L/min
Max. oil flow	400 L/min
Pressure mini. / maxi.	250 - 450 bar
Max. torque *	64520 Nm
Rotation speed with recommended flow	20 rpm
Drainage	Yes
Weight without hitch	750 kg

* Rotation speed depends on oil flow



BIOGAZ versions available. For further information, please contact us :

+33 (0)2 51 48 51 43

Pile shaping - Post driver Auger - Unwinding machine

	Price	Reference
MODEL		
• TRH 1550 (specific for excavator 50 Tons max. / auger Ø 1500 mm max.) - (without auger, without suspension hitch)	44695.00	70674B
COUPLING		
Coupling (or suspension hitch)	1595.00	70675B
AUGERS WITH STRENGTHENED WHORL with driver - Carbide teeth Ø 25 mm - square coupling 130 mm - length 2 m - right pace		
Ø 600 mm - whorl 15 mm thick - 14 teeth Ø 25 mm	5110.00	70670C
Ø 800 mm - whorl 15 mm thick - 18 teeth Ø 25 mm	6805.00	70671C
Ø 1000 mm - whorl 15 mm thick - 22 teeth Ø 25 mm	8680.00	70672C
Ø 1200 mm - whorl 15 mm thick - 26 teeth Ø 25 mm	10435.00	70673C
Ø 1400 mm - whorl 15 mm thick - 30 teeth Ø 25 mm	11665.00	70674C
Ø 1500 mm - whorl 15 mm thick - 32 teeth Ø 25 mm	13230.00	70695C
AUGERS SPECIAL FOR DITCHING - Square coupling 130 mm - Length 1.10 m - right pace		
Ø 580 mm	2180.00	70607D
Ø 780 mm	2245.00	70608D
Ø 980 mm	2640.00	70609D
Ø 1180 mm	2660.00	70610D
Ø 1380 mm	2975.00	70611D
Ø 1480 mm	2990.00	70635E
AUGER EXTENSIONS		
- Without whorl - Square fixing 130 mm - length 1.00 m	1810.00	70675C
- Without whorl - Square fixing 130 mm - length 2.00 m	2395.00	70676C
AUGER WIDENING SYSTEM		
100 mm (+ 200 mm on Ø), teeth Ø 25 mm, a pair	1160.00	70637D
OPTION		
Coils support	860.00	70669I

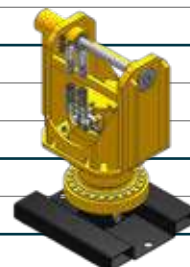

Coils support



CLOTURMATIC RXB



CLOTURMATIC RXB



Air nailing pistol for staples



Rabaud advantages

- 4 models for fencing with 2, 3, 4 or 5 rows of barbed wire in 1 pass.
- Unwind and lay barbed wire in coils (max. 500 m).
- Barbed wire rows are all stretched with same tension thanks to pinions and individual disc brakes.
- Perfect lining of the barbed wires against the post thanks to the 1.00 m hydraulic side shift.
- Slope correctors +/- 30° for setting up the wire parallel to the posts.
- Adjustable row spacing from 145 to 300 mm.
- Air nailing pistol with stainless steel or galvanized staples (in option).
- Loading platform for barbed wire coils.
- Sign lighting kit.

Technical characteristics

MODELS	2 RXB	3 RXB	4 RXB	5 RXB
<i>Number of barbed wire rows</i>	2	3	4	5
<i>Inner coil diameter</i>	95 mm minimum			
<i>Hydraulic offset</i>	1,00 m			
<i>Dimensions without uncoilers (L x W x H)</i>	1,93 x 2,43 x 1,50 m			
<i>Dimensions with uncoilers (L x W x H)</i>	1,93 x 2,43 x 2,38 m			
<i>Weight</i>	950 kg	1030 kg	1110 kg	1190 kg
<i>Drive</i>	Tractor hydraulic pump with 2 hoses and 2 couplers or PTO 540 rpm			
<i>Coupling</i>	Automatic 3-point linkage with round bar category N°2 Tractor from 70 HP			
<i>Electrical drive</i>	12 Volts Electro-hydraulic controls 12 Volts road lighting kit			



Standard equipment

- Automatic coupling with round bar, category N°2.
- Sign lighting kit.
- Hydraulic offset 1 m.
- 2 hydraulic hoses with 2 ½" male valve couplings.



Adjustable row distance



Air compressor

		Price	Reference	
MODELS				
BARBED WIRE UNWINDING MACHINE				
• CLOTURMATIC 2 RXB : Model 2 rows		13180.00	77014A	
• CLOTURMATIC 3 RXB : Model 3 rows		15265.00	77015A	
• CLOTURMATIC 4 RXB : Model 4 rows		17340.00	77016A	
• CLOTURMATIC 5 RXB : Model 5 rows		19395.00	77017A	
OPTIONS				
Tilting corrector (tilting +/- 30°) with wireless radio control	Without hydraulic unit	2840.00	77039A	
	With hydraulic unit (Delivered with oil and shaft)	Without compressor and without air nailing pistol	5125.00	77064A
		With Air compressor (PTO drive) : Automatic unwinder for 8 m pipe – Tool chest – Pressure regulator and manometer –50 L air tanks and with air nailing pistol for 11 mm width staples (loading of 130 staples)	12765.00	77065A
Electro-mechanical time meter (for machine fitted with hydraulic unit - 3-pin socket)		520.00	DIV727	
Staples	Galvanized - width 11 mm - Length 45 mm - Section 1.7 / 1.9 mm - Packed in a box of 8800 staples	380.00	770017	
	Stainless steel - Width 11 mm - Length 45 mm - Section 1.7 / 1.9 mm - Packed in a box of 7500 staples	1345.00	770007	



**Specific mounting on excavator
CONSULT US**



CLOTURMATIC GRX 4020 + 1 row barbed wire unwinder



CLOTURMATIC GRX 4020 + 1 row barbed wire unwinder



CLOTURMATIC GRX 4020 at work

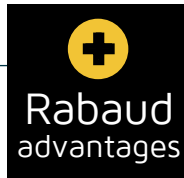

- Unwinds netting rolls wire from 0 up to 2.50 m height (on GRX 8025) and up to 800 mm diameter.
- Barbed wire uncoiled for 1 or 2 rows above the wire netting.
- Hydraulic stretching system for the wire netting.
- Clamp for maintaining tension when fixing or joining rollers.
- Loading platform for putting up the wire netting roll.
- Air nailing pistol with stainless steel or galvanized staples (in option).
- Wire netting always clean and put effortlessly, as the unwinding is made in vertical position.
- Many options:
 - 2-way dual acting valve,
 - Air nailing pistol,
 - Air compressor for the nailing pistol,
 - barbed wire unroller (maximum 2).

Technical characteristics

MODELS	GRX 4020	GRX 8025
<i>Wire netting roll diameter</i>	from 0 up to 400 mm	from 0 up to 800 mm
<i>Roll height : without barbed wire</i>	2.00 m max.	2.50 m max
<i>Roll height : with 1 barbed wire strand</i>	1.52 m max	
<i>Roll height : with 2 barbed wire strand</i>	1.37 m max	1.37 m max
<i>Dimensions (L x W x H)</i>	1,83 x 1,90 x 2,27 m	2,21 x 1,96 x 2,81 m
<i>Weight</i>	645 kg	985 kg
<i>Drive</i>	Tractor hydraulic pump with hydraulic hoses or PTO 540 rpm - flow 34 L/min.	
<i>Coupling</i>	Tractor N°2 3-point hitch with removable pins or Hitch for other carriers Tractor from 80 or 100 HP	



Wire + 2 rows barbed wire



CLOTURMATIC GRX 8025

Standard equipment

- Hydraulic drive with tractor pump.
- Hydraulic tightening system with 2 cylinders, 2 hydraulic hoses and 2 ½" male valve couplings.
- Tension clamp system with 2 cylinders, 2 hydraulic hoses and 2 ½" male valve couplings.



CLOTURMATIC GRX with 2 rows barbed wire uncoiler



Air nailing pistol for staples

MODELS		 Advised Starting up	Price	Reference
WIRE NETTING UNWINDING MACHINE / KNOTED / MULTITWISTED • CLOTURMATIC GRX 4020 (roll size Ø 400 mm - 2,00 m high)				6385.00
WIRE NETTING UNWINDING MACHINE / KNOTED / MULTITWISTED • CLOTURMATIC GRX 8025 (roll size Ø 800 mm - 2,50 m high)			8270.00	77026A
OPTIONS				
2-way dual acting valve			765.00	77022A
Hydraulic unit	With 2-way dual acting valve		1875.00	DIV770
	With 2-way dual acting valve + Air compressor (PTO drive) : Automatic unwinder for 8 m pipe - Tool chest - Pressure regulator and manometer - 50 L air tank + Air nailing pistol for 11 mm width staples (loading of 130 staples)		9830.00	70102B
Compressor kit + Air nailing pistol Air compressor (PTO drive) : Automatic unwinder for 8 m pipe - Tool chest Pressure regulator and manometer - 50 L air tank Air nailing pistol : for 11 mm width staples (loading of 130 staples)			7930.00	77061A
Staples	Galvanized - width 11 mm - Length 45 mm - Section 1.7 / 1.9 mm - Packed in a box of 8800 staples		380.00	770017
	Stainless steel - Width 11 mm - Length 45 mm - Section 1.7 / 1.9 mm - Packed in a box of 7500 staples		1345.00	770007
Electromechanical time meter (for machine with hydraulic unit)			520.00	DIV727
Barbed wire uncoiler	1 row - for CLOTURMATIC GRX 4020 (netting 1.52 m high maximum)		2090.00	77027A
	2 rows - for CLOTURMATIC GRX 4020 (netting 1.37 m high maximum)		3235.00	77028A
	1 row - for CLOTURMATIC GRX 8025 (netting 1.52 m high maximum)		2090.00	77051A
	2 rows - for CLOTURMATIC GRX 8025 (netting 1.37 m high maximum)		3235.00	77052A
Wire netting winder for GRX 8025 only			2880.00	77060A



CLOTURMATIC GRX 4020



CLOTURMATIC GRX 4020



CLOTURMATIC GRX 8025 PE



CLOTURMATIC GRX 8025 PE



CLOTURMATIC GRX 8025 PE



Rabaud
advantages

- Can be fitted to mini-excavators from 6 tons upwards using the quick coupler of your choice.
- Unwinds netting rolls wire from 0 up to 2.50 m height and up to 800 mm diameter.
- Hydraulic wire netting tension system controlled by the operator from the driver's seat.
- Clamp for maintaining tension when fixing or joining rollers.
- Loading platform for putting up the wire netting roll.
- Wire netting always clean and put effortlessly, as the unwinding is made in vertical position.

Technical characteristics

MODEL	GRX 8025 PE
<i>Wire netting roll diameter</i>	from 0 up to 800 mm
<i>Roll height : without barbed wire</i>	2.50 m max
<i>Dimensions (L x W x H)</i>	1,15 x 0,99 x 2,69 m
<i>Weight</i>	460 kg
<i>Drive</i>	Flow 60 L/min. Pressure 220 bar
<i>Coupling</i>	For mini-excavator minimum 6 Tons

	Price	Reference
MODEL		
CLOTURMATIC GRX 8025 PE Ø roll 800 mm - Maximum height 2,50 m (without coupling hitch)	8570.00	77041A
COUPLING HITCH > OBLIGATORY TO DETERMINE		
• Excavator with automatic coupling hitch		See page 230-233
• STANDARD plate 8 holes without bolts for your own adaptation	94.50	70366703L



DEROULMATIC 5 PX with 2 plates equipped with hydraulic winding



DEROULMATIC 5 PX, with 1 hydraulic winding plates



DEROULMATIC 2 PX + irrigation plate + hydraulic winding plate

Rabaud advantages

- The machine is able to unwind 1 up to 5 plain wire coils in one pass.
- The machine can wind 2 plain wire coils thanks to the option hydraulic winding system to mount on the plate (2 hydraulic winding systems max.).
- Different combinations thanks to removable plates.
- Coil diameter adjustable by support.
- Easy coil extraction thanks to retractable plates and conical supports adjustable according to diameter.

Technical characteristics

MODEL	DEROULMATIC PX
<i>Coupling</i>	3-point category 1
<i>Dimensions (L x W x H)</i>	1,61 x 0,91 x 1,64 m
<i>Weight</i>	126 kg to 247 kg
<i>Option winding system : Maximum pressure</i>	200 bar
<i>Option winding system : maximum hydraulic flow</i>	50 L/min
<i>Plate for plain wires</i>	Ø Inner of hose : from 380 mm up to 620 mm Ø Outer maximum of hose : 800 mm
<i>Plate for dripping hose</i>	Ø Inner of hose : from 285 mm up to 640 mm Ø Outer maximum of hose : 910 mm Maximum height of hose : 350 mm

Standard equipment

- 80 mm square tube frame with fixed stands.
- 3-point category 1.
- Coil diameter adjustable by support.



Coils support



Option hydraulic winding system

MODEL	Price	Reference
DEROULMATIC PX - Without plate	1030.00	77050A
OPTIONS		
Plate for plain wires (max. 5 per DEROULMATIC)	525.00	77045A
Additional reception platform for irrigation hose hose adaptability (max. 2)	1180.00	77056A
with 2 hoses and 2 ½ male valve couplers to be fitted on the existing plate (2 maximum) - Compatibility for plain wire plate and dripping hose plate	1100.00	77046A
Coils support - 440 mm loading length, maximum 5 coils (250 kg) - One max. by machine	338.00	77058A
Plate orientation at 75° (not compatible with winding plate lower position)	39.00	77057A
1-way dual acting hydraulic valve*	595.00	77054A
2-way dual acting hydraulic valve*	820.00	77055A

* Mandatory to control winders from the cabin and/or if tractor equipped with only one single acting valve
Possibility of adapting stainless steel coils subject to approval by RABAUD (Consult us).



Agricultural tools

*Washing - Scraping - Debarking -
Feeding - Distributing - Draining*





COMPOST SPREADER	158
Compost and straw spreader FERTIDIS 1000	158
Compost and straw spreader FERTIDIS 3000	159
AUTOMATIC HOOP DRIVER	160
TUNNELMATIC	160
DRAINING SUBSOILER	161
DRAINING subsoiler	161
CUBICLE SWEEPER	162
Cubicle sweeper LOGENET	162
POULTRY HOUSES CLEANER	163
Poultry houses cleaning machine LAVICOLE	163





LOGENET with polypropylene brush



LOGENET with rubber-coated steel broom



Working under stalls

+ Rabaud advantages

- Adaptable to 3-point front or rear linkage, with optional mixed interface for compact loaders, front loaders, etc.
- Large broom: Ø 1.10 m with reversed direction of rotation.
- 2 types of fibre: polypropylene (recommended for carpeted cubicles) or rubber-coated steel (recommended for concrete floors).
- Hydraulic linear offset, ideal for crossing partitions without manoeuvring.
- Large offset up to 1.50 m (2.60 m from tractor centreline): 900 mm hydraulic + 600 mm mechanical (hydraulic optional).
- Very compact, easy to manoeuvre in barns.
- Numerous working options thanks to brush adjustments.
- Operates with 1 double-acting mechanism.

Standard equipment

- Polypropylene or rubber-coated steel brush Ø 1100 mm.
- Hydraulic offset 900 mm + mechanical offset 600 mm by parallelogram
- Tractor 3-point linkage.
- 2 hydraulic hoses with 2 ½" male valve couplings.

Technical characteristics

MODEL	LOGENET
<i>Brush diameter</i>	1 100 mm
<i>Fibre</i>	Polypropylene or steel with rubber coating
<i>Offset</i>	900 mm + 600 mm
<i>Dimensions (L x W x H)</i>	1,48 x 2,16 x 0,95 m
<i>Weight</i>	190 kg (polypropylene) / 205 kg (steel)
<i>Coupling</i>	3-point front or rear tractor - No. 1 and 2 Mixed linkage for other vehicles
<i>Drive</i>	Tractor pump, oil flow from 20 l/min to 60 l/min

600 mm mechanical offset via parallelogram (hydraulic option)

+ 900 mm hydraulically by sliding

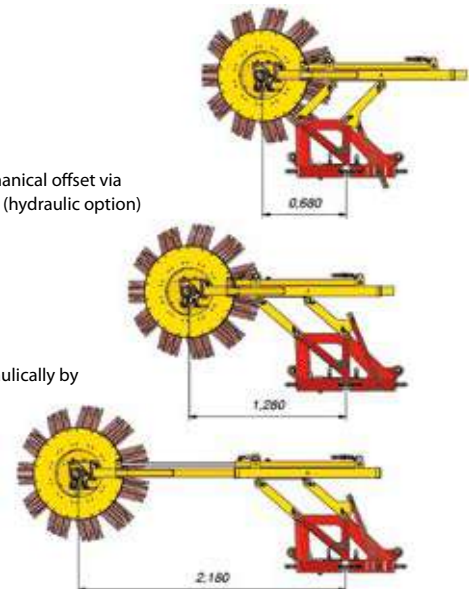

MODELS	Price	Reference
LOGENET 1100		
• With polypropylene brush on the left (can be fitted on the right - please specify when ordering) - Ideal for carpets	4020.00	72019F
• With rubber-coated steel brush on the left (can be fitted on the right - please specify when ordering) - Ideal for concrete	4125.00	72015F
OPTIONS		
600 mm hydraulic offset via parallelogram	487.00	72017F
Mixed interface for adaptation on 2nd carrier, compact loader / front loader / farm valet types	1405.00	72069F



Road and building maintenance tools

Levelling - Snow removing - Sweeping - Weeding brush - Vacuuming - Pruning





SWEEPERS	166
Collecting sweeper TRACTEE 1000 A	166
Aligning sweeper SUPERNET 1200 A	167
Aligning sweepers SUPERNET	168
Aligning sweepers SUPERCHAMPION	170
Front-mounted aligning sweeper PROCHAMPION	172
 Front-mounted aligning sweepers MULTINET	174
 Aligning sweepers on excavator ASTRANET	176
Front-mounted aligning sweepers MEGANET	178
Aligning sweepers on SETRA plate	180
SETRACLEAN sweepers on front and rear SETRA plate	181
Petrol engine aligning sweeper TRAKNET	182
Mechanical aligning sweeper	184
Aligning sweeper TOWED HYDRAULIC 2 BRUSHES	185
Aligning sweeper on forklift SUPERNET INDUS	186
Collecting sweeper TURBONET AUTONOME	187
 Collecting sweepers TURBONET	188
Collecting sweepers URBANET	190
 Sweeping buckets GB	192
WEEDING BRUSHES	194
Weeding brushes on tractor HERBIONET T	194
Weeding brush on arm mower HERBIONET BE	196
 Weeding brush on excavator HERBIONET PE	198
HIGH-PRESSURE CLEANER	200
High-pressure cleaner NHP 600	200
TRAFIC SIGNS CLEANING MACHINE	201
Trafic signs cleaning machine VISIONCLEAN	201
VACUUM CLEANERS	202
Loader leaf vacuums on road trailer WINDY ME	202
Electric leaf hoover on road chassis WINDY E	204
Loader leaf vacuum for side panels WINDY 286 R	205
Loader leaf vacuum for side panels WINDY 491 R	206
SNOW PLOUGHS	208
Snow ploughs SNOWNET	208
GRADER BLADES	210
Grader blades LIGHT, STANDARD & BULL MODELS	210
Grader blades HEAVY DUTY MODEL	212

Compatibility with excavators: 





TRACTÉE 1000 A



TRACTÉE 1000 A



Rabaud advantages

- Adaptable to all carriers with Ø 50 mm ball hitch: ride-on mower, quad, micro-tractor, behind a horse...
- Autonomous operation : mechanical broom drive via two wheels.
- Working width of 1.00 m
- Metal hub and 6-row fibre chevron brush.
- Very strong and very resistant brush thanks to the metal hub.
- Wide and solid wheels : for greater durability and grip.
- 150 L collecting box (useful capacity of 100 L) with manual release.
- Options : side brush, collecting box special for leaves with total capacity of 380 L (useful capacity of 250 L).

Technical characteristics

MODEL	TRACTÉE 1000 A
<i>Coupling</i>	Towing hitch Ø 50 mm for quad...
<i>Brush length</i>	1000 mm
<i>Diameter (inner / outer)</i>	100 mm / 280 mm
<i>Hub</i>	Metal hub and 6-row fibre chevron brush
<i>Brush fibre type</i>	Polypropylene
<i>Angling</i>	No angling
<i>Collecting box capacity</i>	150 L
<i>Dimensions (L x W x H)</i>	2,12 x 1,36 x 0,89 m
<i>Weight</i>	148 kg
<i>Drive</i>	By the wheels with manual unlocking

Standard equipment

- Stands for storage.
- Ball hitch of Ø 50 mm.



TRACTEE 1000 with side brush Emptying the collecting box for leaves

	Price	Reference
MODEL		
TRACTEE 1000 A Chevron brush with 6 rows of polypropylene fibres - Driven by the wheels with manual unlocking - Manual unlocking 150 L collecting box - Sweeper for individual use only, not suitable for communities	3405.00	72001E
OPTIONS		
Side brush Ø 500 mm	520.00	72005E
Collecting box special for leaves (Total capacity 380 L / Useful capacity 250 L)	620.00	72004E
SPARE BRUSHES		
Spare side brush	55.00	055A40
Spare main brush with 6-row fibre chevron brush	310.00	055A39



SUPERNET 1200 A



SUPERNET 1200 A

Rabaud advantages

- Working width of 1.20 m.
- Brush rings made out of polypropylene with long fibres for long-living brush: inner Ø 127 mm / outer Ø 550 mm.
- Hard-wearing brush thanks to the metal nave
- The height of the brush can be adjusted by means of a spacer to compensate for wear.
- Fixed 20° right-hand orientation.
- Pneumatic control wheel swivels 360°.
- Protected hydraulic motor.
- 2 parking stands.

Technical characteristics

MODEL	SUPERNET 1200 A
<i>Brush length</i>	1200 mm
<i>Diameter (inner / outer)</i>	127 mm / 550 mm
<i>Hub</i>	Metal
<i>Brush fibre type</i>	Polypropylene
<i>Dimensions (L x W x H)</i>	1,36 x 1,40 x 0,87 m
<i>Angling</i>	20° on the right
<i>Weight</i>	110 kg
<i>Coupling</i>	N°0 and 1 3-point hitch with welded studs
<i>Drive</i>	Mini-tractor pump with 2 couplers
<i>Oil flow</i>	15 L/min. mini. - 60 L/min. max.
<i>Oil flow recommended</i>	20 L/min
<i>Pressure</i>	180 bar max.

Standard equipment

- Terrace wheel with pneumatic tyres and height-adjustable spacers.
- Hydraulic motor positioned on the left with 2 hydraulic hoses and 2 ½" male valve couplings.
- 2 support stands.



	Price	Reference
MODEL		
SUPERNET 1200 A With polypropylene brush - Drive by tractor pump - With depth control wheel	2335.00	72098D
SPARE BRUSH		
Polypropylene brush Ø 550 mm value for 1 m	235.00	24F002



SUPERNET 1600 A on tractor



SUPERNET 2100 A



SUPERNET 1600 A on compact loader



Rabaud
advantages

- 4 sweeping widths, from 1,60 m up to 2,40 m.
- Adaptable to a 3-point hitch rear tractor, front loader, triangular attachment or compact loader.
- Floating coupling on the top link to follow the road form.
- Mechanical angling coupling allowing to push away the trash on the right or on the left.
- Side-shift separated from angling with quick mechanical sliding.
- Mixed (Polyester/Polypropylene) or polypropylene brush on SUPERNET 2100 et 2400.
- Option side brush Ø 550 mm.
- High resistance for the brush thanks to metal hub/axle.
- Longer fibres for greater durability: inner Ø 127 mm / outer Ø 550 mm.
- 2 rubber-tyred terrage wheels (Ø 200 mm), pivoting and height-adjustable with spacers.

Standard equipment

- Two wheels adjustable in height with spacer.
- Hydraulic motor positioned on the left with 2 hydraulic hoses and 2 ½" male valve couplings.
- Mechanical offset +/- 300 mm.
- Mechanical angling +/- 20°.
- Stands for storage.

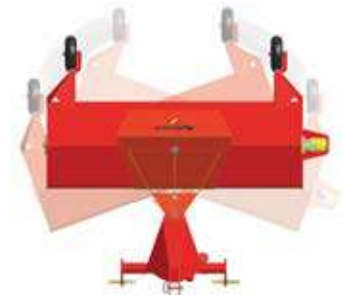

Orientation



Offset

Technical characteristics

MODELS	SUPERNET 1600 A	SUPERNET 1800 A	SUPERNET 2100 A	SUPERNET 2400 A
Brush length	1585 mm	1785 mm	2080 mm	2380 mm
Diameter (inner / outer)	127 mm / 550 mm			
Hub	Metal			
Brush fibre type	Mixed (Polypropylene/polyester)		Mixed (Polypropylene/polyester) or Polypropylene	
Angling	Mechanical on the right 20° / on the left 20° and in the axle			
Offset	Mechanical 300 mm on the right / 300 mm on the left			
Collecting box volume (option)	170 L	190 L	220 L	250 L
Dimensions (L x W x H) with tractor hitch	1,83 x 1,87 x 1,08 m	1,83 x 2,07 x 1,08 m	1,83 x 2,36 x 1,08 m	1,83 x 2,66 x 1,08 m
Weight (3-point version)	220 kg	233 kg	251 kg	270 kg
Coupling	25 HP tractor minimum with 3-point linkage N°1 and N°2. Floating system on the top point / triangle coupling, front and compact loaders			
Drive	Hydraulic carrier pump with 2 ½" male valve couplings			
Oil flow	15 L/min. mini. (30 L/min. mini. with side brush) - 60 L/min. max.			
Pressure	120 bar up to 200 bar maxi			



						Price	Reference			
MODELS										
SUPERNET 1600 A - Without coupling • With mixed brush (polypropylene/polyester)						2275.00	72010H			
SUPERNET 1800 A - Without coupling • With mixed brush (polypropylene/polyester)						2460.00	72012H			
SUPERNET 2100 A - Without coupling • With polypropylene brush • With mixed brush (polypropylene/polyester)						2475.00	72013H			
SUPERNET 2100 A - Without coupling • With mixed brush (polypropylene/polyester)						2575.00	72014H			
SUPERNET 2400 A - Without coupling • With polypropylene brush						2855.00	72056J			
SUPERNET 2400 A - Without coupling • With mixed brush (polypropylene/polyester)						2975.00	72057J			
COUPLING HITCH ➤ OBLIGATORY TO DETERMINE										
Tractor 3-point hitch N°1 & N°2						445.00	72015H			
• Front and compact loaders						1175.00	76415A			
OPTIONS					1600 A	1800 A	2100 A	2400 A		
Triangle hitch - Category to be completed (<i>to be fitted to the 3-point hitch</i>)					•	•	•	•	1250.00	76430A
Polyester side brush Ø 550 mm with hydraulic motor, hoses, 3-way valve - minimum hydraulic flow of 30 l/min					•	•	•	•	1025.00	72039C
Hydraulic angling (<i>only on SUPERNET with tractor 3-point linkage</i>)					•	•	•	•	445.00	72069G
Hydraulic flow divider with pressure relief valve					•	•	•	•	Contact us	DIV720
Anti-projection guard					•				130.00	72040C
						•			140.00	72041C
							•		165.00	72042C
								•	190.00	72058J
Collecting box (<i>only on SUPERNET with tractor 3-point linkage</i>) Be careful when using it on roads!					•				785.00	72043C
						•			825.00	72044C
							•		910.00	72045C
								•	1005.00	72059J
SPARE BRUSHES										
Side brush Ø 550 mm						140.00	055A25			
Polypropylene brush Ø 550 mm value for 1 m						245.00	24F002			
Mixed brush ring (polypropylene/polyester) Ø 550 mm with staple, value for 1 m						295.00	24F003			

35 l/min hydraulic power unit with pump, 30 L tank, oil, transmission, 1DE notched distributor ref.70169A = Ideal for tractors with low hydraulic flow (consult us for RATE)
The ● means compatibility of options with different models.

☑ OPTIONS



Side brush Ø 550 mm hoses, 3-way valve (standard version with central brush)



Collecting box, manual unlocking



Anti-projection guard



SUPERCHAMPION 2100 A with hydraulic offset & orientation+ side brush



SUPERCHAMPION 2400 A with hydraulic orientation and offset with cylinder



SUPERCHAMPION 2400 A with options

+ Rabaud advantages

- 2 sweeping widths, 2.10 or 2.40 m + side brush Ø 700 mm in option.
- Mechanical offset and angling (hydraulic in option) to push away the trash on right or left.
- Hydraulic engine integrated in the metal hub of the brush to save room and for more protection.
- Adaptable to carriers up to 150 l/min thanks to the flow divider option.
- Height-adjustable brush holder for wear compensation
- Brushes with long fibers Ø int. 178 mm / Ø ext. 600 mm.
- Upgradeable thanks to 10 available options : collecting box, watering system, side brush, hydraulic offset and orientation...
- Hitch with permanent oscillation to follow the road conformity.
- 2 puncture-proof wheels (Ø 400 mm), swiveling at 360°.

Technical characteristics

MODELS	SUPERCHAMPION 2100 A	SUPERCHAMPION 2400 A
<i>Brush length</i>	2085 mm	2385 mm
<i>Diameter (inner / outer)</i>	178 mm / 600 mm	
<i>Hub</i>	Metal	
<i>Brush fibre type</i>	Mixed (polypropylene/ polyester) or Polyester	
<i>Orientation (hydraulic in option)</i>	Mechanical rod angling 30° on the right / 30° on the left and in the axls	
<i>Offset (hydraulic in option)</i>	450 mm on the right / 450 mm on the left	
<i>Collecting box volume (option)</i>	315 L	360 L
<i>Watering unit capacity (option)</i>	300 L (2 x 150 L)	
<i>Number of nozzles</i>	8 sprays	10 sprays
<i>Dimensions (L x W x H)</i>	2,49 x 2,24 x 1,10 m 2,49 x 2,40 x 1,10 m with hydraulic collecting box	2,49 x 2,54 x 1,10 m 2,49 x 2,70 x 1,10 m with hydraulic collecting box
<i>Weight (without option)</i>	451 kg	476 kg
<i>Coupling</i>	Rear 3-point linkage N°2 with removable pins	
<i>Drive</i>	Tractor pump with 2 couplers 1/2 or PTO 540 rpm, 40 L/min.	
<i>Flow 1 hydraulic motor</i>	20 l/min - 60 l/min (150 l/min with flow divider)	
<i>Flow 2 hydraulic motor</i>	-	61 L/min. mini. - 120 L/min. max.
<i>Pressure</i>	120 bar up to 200 bar maxi	

Standard equipment

- With mixed or polypropylene brush (Polyester/polypropylene).
- 2 solid, puncture-proof Ø 400 mm digging wheels, with grease lubricator.
- Mechanical oscillation.
- Mechanical angling +/- 30°.
- Mechanical offset +/- 450 mm.
- 2 hydraulic hoses with 2 ½" male valve couplings.
- Brush adjustment by crank handle.



SUPERCHAMPION 2400A with specific painting, watering and light kit



SUPERCHAMPION 2400 A with hydraulic orientation and offset with cylinder

MODELS	Price Reference		Price Reference		
	SUPERCHAMPION 2100 A		SUPERCHAMPION 2400 A		
SUPERCHAMPION with 1 hydraulic motor (for carrier with oil flow < 60 L/min.)					
• With mixed brush (polypropylene / polyester)	5295.00	72015K	6470.00	72017K	
• With polyester brush	5590.00	72016K	6735.00	72018K	
SUPERCHAMPION with 2 hydraulic motor (for carrier with oil flow > 60 L/min.)					
• With polyester brush			8430.00	72096E	
COLLECTING BOX > MANDATORY TO DETERMINE					
Anti-spatter guard WITHOUT collecting box	205.00	72004K	205.00	72006K	
Mechanical collecting box (not suitable for use on roads)	1320.00	72076C	1320.00	72077C	
Hydraulic collecting box with 3rd depth control wheel	3125.00	72002K	3125.00	72003K	
WATERING*					
Pressure watering 12 V with 2 water tanks of 150 L each (power supply needed)	on the main brush*	2080.00	72090C	2080.00	72091C
	on the collecting box	2080.00	72008K	2080.00	72009K
Pressure watering on side brush with 2 sprays	165.00	72097C	400.00	72097C	
OPTIONS (without valve)					
Side brush Ø 700 mm in polyester with 3-way valve	(Sweeper without collecting box)	1570.00	72081C	1570.00	72081C
	(Sweeper with collecting box)	1580.00	72082C	11580.00	72082C
Side brush Ø 700 mm made of polyester with hydraulic lifting		1650.00	72033K	1650.00	72033K
Hydraulic offset		635.00	72094E	635.00	72094E
Hydraulic orientation		405.00	72079C	405.00	72079C
Hydraulic power pack with pump delivering 40 l/min (plan number of hydraulic spool valves accordingly)		1725.00	70145A	1725.00	70145A
Hydraulic valves with support and hydraulic hoses	1-way valve dual-acting	465.00	72083C	465.00	72083C
	2-way valve dual-acting	650.00	72084C	650.00	72084C
	3-way valve dual-acting	750.00	72085C	750.00	72085C
	4-way valve dual-acting		-	1045.00	72007K
Electro-hydraulic control with radio control		3315.00	72011K	3315.00	72011K
50 l/min hydraulic flow divider (maximum oil flow 150 l/min) with 190 bar pressure relief valve. Caution : single direction rotation for brush		530.00	72098J	530.00	72098J
Lithium battery electric hour meter		505.00	72715A	505.00	72715A
3rd terrage wheel under hitch		515.00	72019K	515.00	72019K
12 V worksite signs kit with retroreflective tape, 2 lumifog... (requires power supply)		340.00	72095C	340.00	72095C
12 V lighting kit with license plate holder with lighting, 2 taillights... (requires power supply)		635.00	72072C	635.00	72072C
Specific painting		185.00	72009C	185.00	72009C
EPOXY painting		430.00	72033G	430.00	72033G
SPARE BRUSHES					
Side brush Ø 700 mm	In polyester	175.00	055A10	175.00	055A10
Mixed brush ring (polypropylene/polyester) Ø 600 mm, value for 1 m		340.00	24F006	340.00	24F006
Polyester brush ring Ø 600 mm, value for 1 m		480.00	24F004	480.00	24F004

* 8 sprayers for model 2100 - 10 sprayers for model 2400



Hydraulic orientation and offset by cylinder



Side brush Ø 700 mm with rotation reverser



Hydraulic collecting box



Collecting box, mechanical emptying



Watering by pressure, electrical pump 12V, 2 tanks of 150L, with spray line*



Hydraulic unit with dual-acting valve



12 Volts lighting kit



3rd terrage wheel under hitch



PROCHAMPION 2500 A With high-flow watering spray line and road sign kit



PROCHAMPION 2500 A With high-flow watering spray line and road sign kit



PROCHAMPION 2500 A with telescopic mixed hitch



- Large sweeping widths: 2 m or 2.50 m.
- Adaptation on front 3-point linkage or on telescopic.
- Robust frame for intensive work
- 1 or 2 hydraulic motor(s) depending on the carrier oil flow (120 L/min. max.).
- Floating coupling to follow road form thanks to the swiveling system
- 30° mechanically swivelling hitch (hydraulic in option).
- +/- 420 mm mechanical offset (hydraulic in option) separate from angling
- Hydraulic engine integrated in the metal hub of the brush to save room and for more protection.
- Wide brush with polyester fibre for better lasting (inner size: Ø 178 mm / outer size: Ø 600 mm).
- 2 height-adjustable, swivelling puncture-proof wheels (Ø 250 mm).
- Pressure watering option to connect directly to your tank.

Technical characteristics

MODELS	PROCHAMPION 2000 A	PROCHAMPION 2500 A
Brush length	1980 mm	2460 mm
Brush diameter (inner / outer)	178 mm / 600 mm	
Hub	Metal	
Brush fibre type	Polyester	
Offset	420 mm right & left (only on tractor)	
Angling	+/- 30°	
Oscillation	On floating coupling	
Dimensions (L x W x H)	1,67 x 2,09 x 1,26 m	1,67 x 2,55 x 1,26 m
Weight (without option)	640 kg	660 kg
Coupling	No. 2 front 3-point hitch with removable bar	
Flow 1 hydraulic motor	30 L/min. mini. - 60 L/min. max.	
Flow 2 hydraulic motor	61 L/min. mini. - 120 L/min. max.	

Standard equipment

- Anti-projection guard.
- 3-point linkage with oscillating top link.
- 2 control tyre wheels (diameter 250 mm), swiveling and adjustable in height.
- Brush rings with extra long polyester fibre for longer lifespan.
- Mechanical angling +/- 30°.
- Mechanical offset +/- 420 mm (only on tractor).
- 2 hydraulic hoses with 2 1/2" male valve couplings.



PROCHAMPION on tractor front 3-point linkage

		Price	Reference	Price	Reference	
MODELS		PROCHAMPION 2000 A		PROCHAMPION 2500 A		
PROCHAMPION for tractor with 1 hydraulic motor (for carrier with oil flow < 60 L/min.) • Without hydraulic valves - With polyester brush		7765.00	72083E	8195.00	72082E	
PROCHAMPION for tractor with 2 hydraulic motor (for carrier with oil flow > 60 L/min.) • Without hydraulic valves - With polyester brush		8490.00	72085E	9205.00	72084E	
OPTIONS						
Hydraulic offset		865.00	72032E	865.00	72032E	
Hydraulic orientation		950.00	72086E	950.00	72086E	
Electro-hydraulic control with radio-control	Sweeper with 1 hydraulic motor	2-way valve dual-acting	2820.00	72066E	2820.00	72066E
		3-way valve dual-acting	3275.00	72067E	3275.00	72067E
	Sweeper with 2 hydraulic motor	2-way valve dual-acting	3700.00	72069E	3700.00	72069E
		3-way valve dual-acting	4050.00	72070E	4050.00	72070E
Hydraulic valve	6-way valve with electric extension 5 m long		850.00	72035G	850.00	72035G
	8-way valve with electric extension 5 m long		1040.00	72036G	1040.00	72036G
180 bar pressure limiter (for sweeper with only 1 motor)		240.00	72022J	240.00	72022J	
High pressure watering line with 4 sprayers (without water tank)		445.00	72064E	445.00	72064E	
Scrape blade		-		3195.00	72061J	
Linkage n°3 with swinging drawbar		250.00	72071E	250.00	72071E	
Mixed hitch for second carrier like a telehandler		1160.00	72064F	1160.00	72064F	
12 V worksite signs kit with retroreflective tape, 2 lumifog... (requires power supply)		380.00	72095C	380.00	72095C	
Specific painting		185.00	72009C	185.00	72009C	
EPOXY painting		430.00	72033G	430.00	72033G	
SPARE BRUSH						
Polyester brush ring Ø 600 mm, value for 1 m		480.00	24F004	480.00	24F004	

✓ OPTIONS



Linkage n°3 with swinging drawbar



Mixed hitch for second carrier like a telescopic



High pressure watering line, 4 sprayers

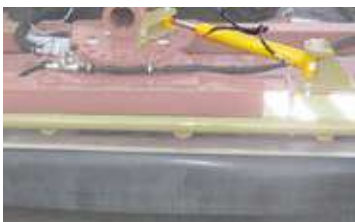

Hydraulic angling



Hydraulic offsetting



Scrape blade



MULTINET 2400 with options side brush and hydraulic collecting box



MULTINET 2100 with road sign kit + anti-spatter guard



Available on SETRA plate - Contact us

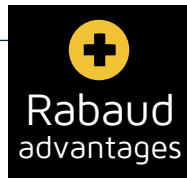

- 2 lengths : 2,10 m or 2,40 m + side brush Ø 700 mm in option (left or right).
- Suitable for telescopic handlers, loaders, backhoe loaders, 3-point front tractors from 70 to 120 HP, front loaders.
- "2in1" function : collecting the trash (when box is closed) or lining up the trash on the right or on the left (when box is lifted).
- Hydraulic collecting box (option).
- Mechanical angling (hydraulic in option) +/- 25° with exclusive synchronized side offset
- Driven by one or two hydraulic motors: ideal for high-volume tractors.
- Hydraulic engine integrated in the metal hub of the brush to save room and for more protection.
- 2 height-adjustable, 360° swivel puncture proof wheels.
- Hitch with permanent oscillation to follow the road conformity.

Technical characteristics

MODELS	MULTINET 2100	MULTINET 2400
<i>Brush length</i>	2100 mm	2400 mm
<i>Diameter (inner / outer)</i>	178 mm / 600 mm	
<i>Hub</i>	Metal	
<i>Brush fibre type</i>	Mixed (Polypropylene/polyester) or Polyester (in option)	
<i>Angling</i>	Hole bar for 25° left and right mechanical orientation	
<i>Floating oscillation</i>	+/- 5°	
<i>Collecting box volume (option)</i>	350 L	400 L
<i>Water tank (option)</i>	100 L	100 L
<i>Dimensions without collecting box (L x W x H)</i>	1,15 x 2,20 x 1,03 m	1,15 x 2,50 x 1,03 m
<i>Dimensions with lifted collecting box (L x W x H)</i>	1,72 x 2,20 x 1,40 m	1,72 x 2,50 x 1,40 m
<i>Dimensions with working collecting box (L x W x H)</i>	1,77 x 2,20 x 1,03 m	1,77 x 2,50 x 1,03 m
<i>Weight (without option)</i>	From 411 up to 438 kg	From 437 up to 457 kg
<i>Coupling</i>	Telehandler/Backhoe/Loader/front loader/3-point hitch front N°2 and N°3, Tractor from 70 up to 150 HP	
<i>Flow 1 hydraulic motor</i>	20 l/min - 60 l/min (150 l/min with flow divider)	
<i>Flow 2 hydraulic motor</i>	61 l/min. mini. - 120 l/min. max.	
<i>Pressure</i>	120 bar up to 200 bar maxi	



Standard equipment

- Mixed brush (polypropylene/polyester).
- 2 control wheels, swiveling 360° and adjustable in height with crank.
- Mechanical angling +/- 25°.
- Floating coupling.
- 2 hydraulic hoses with 2 female valve couplers 3/8.



Options : road signs kit + collecting box



Options : watering unit + road signs kit (Polyester brush available)

MODELS	Price		Reference				
	MULTINET 2100		MULTINET 2400				
SWEEPER with 1 hydraulic motor (for carrier with oil flow < 60 L/min.) (without hitch and hydraulic valves) • With mixed brush (polypropylene/polyester)	6275.00	72006G	6450.00	72008G			
SWEEPER with 2 hydraulic motor (for carrier with oil flow > 60 L/min.) (without hitch and hydraulic valves) • With mixed brush (polypropylene/polyester)	7525.00	72018G	7695.00	72020G			
COUPLING HITCH > OBLIGATORY TO DETERMINE							
• Telescopic, backhoe loader, Loader, skid steer loader	820.00	78501A	820.00	78501A			
• 3-point linkage front (for tractor between 70 HP and 150 HP)	1000.00	72025G	1000.00	72025G			
• Mini-excavator with 8-holes plate (Quick-fit coupling to be determined, see pages 230-233)	695.00	78502A	695.00	78502A			
• MECALAC CONNECT or ACTIV LOCK fastener	1015.00	78504A	1015.00	78504A			
• Forks (a pair)	1540.00	78503A	1540.00	78503A			
OPTIONS							
Anti spatter guard (OBLIGATORY IF NO COLLECTING BOX)	370.00	72049G	370.00	72050G			
Hydraulic collecting box (not compatible with anti spatter guard)	2675.00	72097F	2905.00	72098F			
Kit to hold the collecting box when sweeping – For telescopic Merlo, Bobcat, FDI-Sambron, Kubota skidsteer...	240.00	72052G	240.00	72052G			
Hydraulic angling +/- 25° with synchronised sideshift	440.00	72017G	440.00	72017G			
50 l/min hydraulic flow divider (maximum oil flow 150 l/min) with 190 bar pressure relief valve. Caution : single direction rotation for brush	530.00	72098J	530.00	72098J			
6-way valve	with electric extension 5 m long	750.00	72037G	750.00	72037G		
	with winder and electric extension 15 m long	1160.00	72038G	1160.00	72038G		
Side brush Ø 700 mm with 3-way valve	without collecting box	In polyester	Right	1620.00	72095G	1620.00	72095G
			Left	1620.00	72096G	1620.00	72096G
	steel/rilsan	Right	1675.00	72033H	1675.00	72033H	
		Left	1675.00	72034H	1675.00	72034H	
	with collecting box	In polyester	1405.00	72099F	1405.00	72099F	
		steel/rilsan	1440.00	72004H	1440.00	72004H	
12 V worksite signs kit with retroreflective tape, 2 lumifog... (requires power supply)		465.00	72046E	465.00	72046E		
Specific painting		185.00	72009C	185.00	72009C		
EPOXY painting		425.00	72033G	425.00	72033G		
WATERING							
Kit 100-litre water tank	Coupling hitch for telehandler, loader, tractor, excavator...	915.00	72022G	915.00	72022G		
	For forks attachment	805.00	72023K	805.00	72023K		
Spray line kit	on the main brush*	255.00	72049E	255.00	72048E		
	on the collecting box (only adaptable with collecting box)	290.00	72010G	290.00	72045G		
Spray line kit on side brush (only adaptable with side brush)		155.00	72012G	155.00	72012G		
Electric pump	12 Volts (requires a power supply)	510.00	72050E	510.00	72050E		
	24 Volts (requires a power supply)	515.00	72051E	515.00	72051E		
Water pump control box		425.00	72068G	425.00	72068G		
Spraying line kit high flow with 4 sprayers (without tank) - if collecting box, it should be open		565.00	72053G	565.00	72053G		
SPARE BRUSHES							
Side brush Ø 700 mm	In polyester	175.00	055A10	175.00	055A10		
	steel/rilsan	285.00	055A42	285.00	055A42		
Brush Ø 600 mm, value for 1 m	mixed (polypropylene/polyester)	330.00	24F006	330.00	24F006		
	In polyester	480.00	24F004	480.00	24F004		

* 8 sprayers for model 2100 - 10 sprayers for model 2400



ASTRANET 1500 PE



ASTRANET 2000 PE



ASTRANET 1500 PE floating hitch

- Adaptation on excavators 4 up to 12 Tons.
- 2 models for sweeping widths of 1.50 m or 2 m. Ideal for sweeping on public works sites.
- Sweeper equipped with coupling "FloatSweep" to follow road form.
- Robust frame for intensive work.
- Hydraulic motor for high flow up to 120 L/min.
- Inserted hydraulic motors in the metal brush hub for compact transport size and for engine protection.
- Mixed brush Ø 600 mm (polyester + polypropylene).
- 2 parking stands.
- Watering in option with 2 tanks of 150 L each.

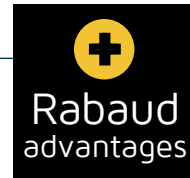

Technical characteristics

MODELS	ASTRANET 1500 PE	ASTRANET 2000 PE
Coupling	Excavator 4 up to 12 Tons	
Brush length	1500 mm	2000 mm
Diameter (inner / outer)	178 / 600 mm	
Hub	Metal	
Brush fibre	Mixed (Polypropylene/polyester)	
Dimensions (L x W x H)	1,03 x 1,64 x 1,08 m	1,03 x 2,13 x 1,08 m
Weight (without linkage)	310 kg (without options)	350 kg (without options)
Flow 1 hydraulic motor	25 L/min. mini. - 120 L/min. max.	
Maximum pressure	250 bar	

Standard equipment

- Mixed brush (polypropylene/polyester).
- Hitch "Floatsweep" to follow road form.
- 1 hydraulic motor.
- Integrated flow divider / pressure relief valve.



				Price	Reference
MODELS					
ASTRANET 1500 PE for EXCAVATOR for carrier with hydraulic flow from 25 to 120 l/min • With mixed brush (polypropylene/polyester)				4945.00	72051J
ASTRANET 2000 PE for EXCAVATOR for carrier with hydraulic flow from 25 to 120 l/min • With mixed brush (polypropylene/polyester)				5880.00	72071J
COUPLING HITCH > OBLIGATORY TO DETERMINE					
• EXCAVATOR with quick-fit coupling				See page 230-233	
• STANDARD plate 8 holes without bolts for your own adaptation				80.00	70366703L
OPTIONS				ASTRANET 1500 PE	ASTRANET 2000 PE
Pressure watering (kit electrical pump 12V - electrical power needed) - 2 water tanks of 150 L with automatic start of watering AUTOFLOW				•	
					•
				1995.00	72052J
				2015.00	72072J
SPARE BRUSH					
Brush Ø 600 mm, value for 1 m	mixed (polypropylene/polyester)			•	•
	In polyester			•	•
				330.00	24F006
				480.00	24F004

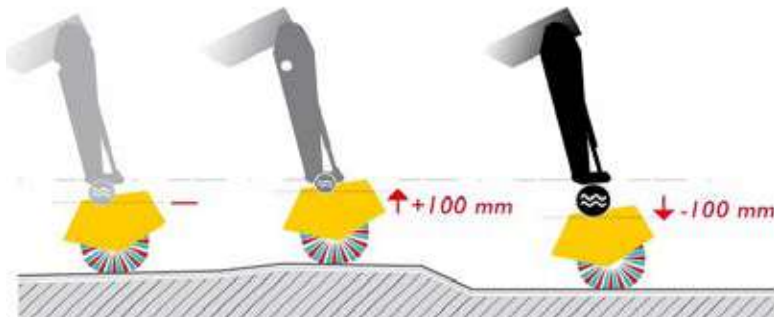

Coupling hitch equipped by "FloatSweep" fastener for tracking road compliance.



✓ OPTIONS



Option pressure watering.
2 water tanks of 150L. 12V or 24V electrical socket.



Quick fit coupling for excavator.
Adaptation on all type of carrier and any coupling.



Specific painting



MEGANET 3500 on loader



MEGANET 3000



MEGANET 3000

- 3 large sweeping widths: 3 m, 3.50 m or 4.00 m.
- Adaptation on loaders up to 20 Tons or on front 3-point for tractors from 150 HP.
- Robust frame for intensive work
- 2 hydraulic motors with high torque.
- Long fibre polyester brush with reinforced section (inner size: Ø 254 mm / outer size: Ø 800 mm).
- Mechanical orientation (hydraulic in option) +/- 25° to right and left.
- Floating coupling to follow road form thanks to the swiveling system.
- 2 puncture proof depth control wheels, Ø 600 mm, 200 mm wide
- Anti-projection guard adjustable in height.



MEGANET 3000 with collecting box, watering system and specific painting

Technical characteristics

MODELS	MEGANET 3000	MEGANET 3500	MEGANET 4000
<i>Brush length</i>	2880 mm	3480 mm	3900 mm
<i>Diameter (inner / outer)</i>	254 mm / 800 mm		
<i>Hub</i>	Metal without drive shaft bearing		
<i>Brush fibre type</i>	Reinforced polyester		
<i>Collecting box volume (option)</i>	1000 L	1170 L	-
<i>Angling</i>	Mechanical or hydraulic orientation +/- 25°.		
<i>Dimensions (L x W x H)</i>	2,00 x 3,15 x 1,49 m	2,00 x 3,75 x 1,49 m	2,00 x 4,17 x 1,49 m
<i>Weight</i>	1320 kg	1600 kg	1700 kg
<i>Coupling</i>	Front 3-point hitch N°3 - Loader up to 20 Tons		
<i>Drive</i>	Carrier hydraulic pump		
<i>Hydraulic flow</i>	60 l/min min. - 120 l/min max. (250 l/min on request)		
<i>Pressure</i>	210 bar max.		

Standard equipment

- Polyester brush with reinforced brush Ø 800 mm.
- 2 hydraulic hoses without couplers.
- 2 adjustable depth control wheels, Ø 600 mm, 200 mm wide.
- Mechanical or hydraulic orientation +/- 25° to determine.
- Double anti-projection guard.

	Price	Reference	Price	Reference	Price	Reference
MODELS	MEGANET 3000		MEGANET 3500		MEGANET 4000	
SWEEPER with 2 HYDRAULIC motors (for carriers with oil flow > 60 L/min) • With polyester reinforced brush	14680.00	72017H	16560.00	72018H	19380.00	72019H
COUPLING HITCH > OBLIGATORY TO DETERMINE						
• Wheel or track loader up to 20 Tons	1520.00	76416A	1520.00	76416A	1520.00	76416A
• Front 3-point hitch (between 150 and 250 HP)	1775.00	72020H	1775.00	72020H	1775.00	72020H
ANGLING > OBLIGATORY TO DETERMINE						
• Mechanical orientation +/- 25°	1040.00	72049H	1040.00	72049H	1040.00	72049H
• Hydraulic orientation with 2 cylinders +/- 25°	1140.00	72029H	1140.00	72029H	1140.00	72029H
OPTIONS						
Collecting box	7120.00	72007J	7830.00	72029J	-	-
Anti spatter guard (OBLIGATORY WITHOUT COLLECTING BOX)	830.00	72018J	875.00	72031J	-	-
Side brush Ø 700 mm with 3-way valve	with collecting box	Right	2085.00	72013K	2085.00	72013K
		Left	2085.00	72014K	2085.00	72014K
6-way hydraulic valve with lead extension 5.00 m long - 24 Volts	760.00	72048H	760.00	72048H	760.00	72048H
24 V pressure watering with 300 L water tank	2085.00	72030J	2085.00	72030J	-	-
Spray line kit	on the main brush*	300.00	72040J	423.00	72042J	-
	on the collecting box	385.00	72041J	510.00	72043J	-
High flow watering with spraying line and firefighter connection (without tank)	565.00	72032H	565.00	72032H	565.00	72032H
LED Lighting with magnetic holders	875.00	72021H	875.00	72021H	875.00	72021H
12 V worksite signs kit with retroreflective tape, 2 lumifog... (requires power supply)	550.00	72047H	550.00	72047H	550.00	72047H
Specific painting	185.00	72009C	185.00	72009C	185.00	72009C
EPOXY painting	425.00	72033G	425.00	72033G	425.00	72033G
SPARE BRUSH						
Polyester brush Ø 800 mm, value for 1 m	860.00	24F018	860.00	24F018	860.00	24F018

* 10 sprayers for MEGANET 3000 - 12 sprayers for MEGANET 3500





SETRANET 2100



SETRANET 2100



SETRANET - at transport



- Adaptable to SETRA F1 and F2 type plates for carriers under 10 Tons.
- 2 available sweeping widths: 1.80 m or 2.10 m.
- Suspension parallelogram to follow the road form, with single-acting hydraulic lifting cylinder.
- Right / left lateral oscillation.
- Hydraulic orientation 20° right + 20° left with 2 DE hydraulic cylinders, with pressure limiter.
- Mixed brush (polyester / polypropylene).
- Brush with long fibers, inner Ø: 127 mm, outer Ø: 550 mm
- Greater robustness: chassis and headstock made entirely of welded steel.
- 2 puncture-proof rubber wheels, Ø 200 mm.

Technical characteristics

MODELS	SETRANET 1800 A	SETRANET 2100 A
<i>Brush length</i>	1785 mm	2080 mm
<i>Diameter (inner / outer)</i>	127 mm / 550 mm	
<i>Hub</i>	Metal	
<i>Brush fibre type</i>	Mixed (Polypropylene/polyester)	
<i>Offset</i>	Mechanical 300 mm on the right / 300 mm on the left	
<i>Hydraulic orientation</i>	+/- 20°	
<i>Dimensions (L x W x H)</i>	1,37 x 2,07 x 0,87 m	1,37 x 2,37 x 0,87 m
<i>Weight</i>	207 kg	237 kg
<i>Coupling</i>	Setra plate type F1 or F2	
<i>Drive</i>	Hydraulic carrier pump with couplers in accordance with NF EN 15432	
<i>Hydraulic flow</i>	15 L/min. mini. - 60 L/min. max.	
<i>Pressure</i>	120 bar up to 200 bar maxi	

Standard equipment

- Mixed brush (polyester / polypropylene).
- Two wheels adjustable in height with spacer.
- +/- 300 mm mechanical offset and +/- 20° hydraulic angling.
- Stands for storage.

		Price	Reference
MODELS			
SETRANET 1800		3045.00	72094H
SETRANET 2100		3185.00	72095H
COUPLING HITCH > OBLIGATORY TO DETERMINE			
• Coupling hitch for F1 SETRA plate		3695.00	72096H
• Coupling hitch for F2 SETRA plate		3560.00	72097H
OPTIONS	SETRANET 1800 A	SETRANET 2100 A	
Anti-projection guard	•		140.00 72041C
		•	165.00 72042C
Polyester side brush Ø 550 mm with hydraulic motor, hoses, 3-way valve - minimum hydraulic flow of 30 l/min	•	•	1025.00 72039C
Road signs kit 12/24 Volts	•	•	490.00 72098H
Mach 7 multi-coupling	•	•	725.00 72091E
SPARE BRUSHES			
Side brush Ø 550 mm		140.00	055A25
Mixed brush ring (polypropylene/polyester) Ø 550 mm with staple, value for 1 m		295.00	24F003



SETRACLEAN with collecting box



SETRACLEAN

+
Rabaud
advantages

- Sweeper suitable for trucks over 10 Tons or backhoe loaders thanks to SETRA plate mounting.
- 2 models for sweeper widths of 2.10 m or 2.40 m.
- Reduced parallelogram of suspension to limit overhanging in a raised position.
- Angling max. 45° on the right and 45° on the left, with a hydraulic anti-hooking security.
- Hydraulic offset side of 450 mm on the left and on the right.
- "2in1" function : collecting the trash (when box is closed) or lining up the trash on the right or on the left (when box is lifted).

Technical characteristics

MODELS	SETRACLEAN 2100	SETRACLEAN 2400
Coupling	SETRA plate with SE hydraulic lift	
Brush length	2100 mm	2400 mm
Diameter (inner / outer)	178 / 600 mm	
Hub	Metal	
Brush fibre type	Mixed (polypropylene/ polyester) or Polyester	
Transfer dimensions (L x W x H)	2,17 x 2,20 x 1,40 m	2,17 x 2,50 x 1,40 m
Weight	550 kg	570 kg
Flow 1 hydraulic motor	From 20 to 60 L/min. at 200 bar	
Orientation (hydraulic in option)	Right 45° / left 45° maxi.	
Offset (hydraulic in option)	450 mm on the right / 450 mm on the left maxi.	
Collecting box (in option)	Real volume: 350 liters	Real volume: 400 liters



Specific conditions :
Consult us

Standard equipment

- Articulated cable tray & hydraulic hoses.
- Rubber wheels Ø 250 swiveling 360°.
- 5° right/left mechanical oscillation via reinforced pivot axis.
- Reinforced frame for intensive work (8 mm thick side covers).



SETRACLEAN - Mounting on backhoe loader with rear SETRA plate + one mounted on the front loader



SETRACLEAN - Mounting on street truck



TRAKNET 2100



TRAKNET 2100

- Sweeper to adapt on all vehicles, car, van, city works carrier...
- A design that allows rapid adaptation for emergency intervention on site.
- Travel speed up to 130 km/h. Sweeping speed from 0 to 15 km/h.
- Side offset of the brush 600 mm hydraulic.
- Electro-hydraulic distributor for raising and lowering the brushes, controlled from the driver's cab.
- Hydraulic right/left brush adjustment for waste disposal.
- Mechanical oscillation on the right and on the left complies with the road conformity.
- Removable bearing carrier which ensures a quick release of the brush.
- Roadside equipment: parking lights, direction indicators, retro-reflectors, illuminated number plate holder. Optional extras: rotating beacon, centralised lubrication.
- Road frame complying with European standard 2007/46/CE(RCE).



Technical characteristics

MODEL	TRAKNET 2100
<i>Brush length</i>	2100 mm
<i>Brush diameter</i>	600 mm
<i>Hub</i>	Metal
<i>Brush fibre type</i>	Polyester
<i>Right / left offset</i>	600 mm on the right
<i>Orientation</i>	+/- 25°
<i>Oscillation</i>	+/- 5,5°
<i>Brushing speed</i>	0 to 15 km/h
<i>Dimensions (L x W x H)</i>	4,53 x 2,22 x 1,20 m
<i>Weight (without options)</i>	745 kg
<i>Coupling</i>	Commercial vehicles, vans, 4x4s, site machinery...
<i>Drive</i>	Hydraulic drive from thermal power unit
<i>Wheels (Number: 2)</i>	175/80 R14C
<i>Travel speed</i>	130 km/h max.

Standard equipment

- Anti-projection guard.
- Height-adjustable jockey wheel.
- Hooking ball Ø 50 mm and Ø 68 mm ring.
- Mudguard.

	Price	Reference
MODEL		
TRAKNET 2100 2.10 m wide - Polyester brush - Articulated drawbar - Radio control - Hydraulic rotation - Hydraulic offset - Cyclist protection	19750.00	72077G
DRIVE > OBLIGATORY TO DETERMINE		
10.5 kW / 14 HP Briggs & Stratton petrol engine (3-year WARANTEE)	1750.00	70189A
8.6 kW / 11.7 HP HONDA petrol engine (3-year warranty)	2260.00	70113B
OPTIONS		
Oil cooler	1050.00	72092G
Automatic centralized lubrication with adjustable frequency	2070.00	72091G
12 / 24 V revolving light with LED	290.00	72093G
Spare wheel (to be loaded on carrier)	220.00	72094G
Specific painting	185.00	72009C
Polyester brush Ø 600 mm with staples, value for 1 m	480.00	24F004



TRAKNET 2100 sweeper



TRACTEE 1800A



TRACTEE 1800A



TRACTEE 1800A for transport



- Sweeper to adapt on all vehicles, car, van, city works carrier...
- A design that allows rapid adaptation for emergency intervention on site.
- Travel speed up to 25 km/h. Sweeping speed from 5 to 10 km/h.
- 500 mm brush right side shift by drawbar turning (left side shift on request).
- Mechanical oscillation on the right and on the left complies with the road conformity.
- Removable bearing carrier which ensures a quick release of the brush.

Technical characteristics

MODELS	TOWED 1800 A MECHANICAL	TOWED 2000 C MECHANICAL
<i>Brush length</i>	1800 mm	2000 mm
<i>Brush diameter</i>	550 mm	
<i>Hub</i>	Metal	
<i>Brush fibre type</i>	Mixed (polypropylene/polyester)	
<i>Right / left offset</i>	500 mm right	
<i>Orientation</i>	Permanent 25°	
<i>Oscillation</i>	+/- 8°	
<i>Brushing speed</i>	5 to 10 km/h	
<i>Dimensions (L x W x H)</i>	4,16 x 1,97 x 1,02 m	4,10 x 2,24 x 1,10 m
<i>Weight (without options)</i>	610 kg	755 kg
<i>Coupling</i>	Commercial vehicles, vans, 4x4s, site machinery...	
<i>Drive</i>	Mechanical through wheels	
<i>Wheels (Number: 2)</i>	175/70 R13	
<i>Travel speed</i>	25 km/h	

Standard equipment

- Anti-projection guard.
- Height-adjustable jockey wheel.
- Hooking ball Ø 50 mm and Ø 68 mm ring.
- Mudguard.
- Spare wheel mounted on the sweeper.

		Price	Reference
MODEL			
MECHANICAL TOWED 1800 A 1,80 wide - Mixed brush (polypropylene/polyester) - Automatic clutch release - Mechanical drive through the wheels - Side offset of 500 mm - Anti spatter guard - Coupling : hooking ball Ø 50 mm and ring Ø 42x68 mm		11960.00	72067D
MECHANICAL TOWED 2000 C Width 2,00 m - Mixed broom (polypropylene/polyester) - Automatic Clutch - Mechanical drive through the wheels - Offset of 500 mm - Mudguard - Ball attachments Ø 50 mm / ring Ø 42 x 68 mm		12450.00	72026K
OPTIONS			
Watering Pressure with 2 tanks of 150 L and 6 sprayers	12V Electric pump	2225.00	72094D
	24V Electric pump	2225.00	72095D
12 Volts / 24 Volts lighting kit		1030.00	72070D
Specific painting		185.00	72009C
Mixed brush (Polyester/Polypropylene) Ø 550 mm with staples, value for 1 m		295.00	24F003



TOWED HYDRAULIC 2 BRUSHES



**Rabaud
advantages**

- Sweeper with fixed drawbar that can be towed by any type of vehicle: van, worksite machinery, etc.
- A design that allows rapid adaptation for emergency intervention on site.
- Sweeping speed from 5 to 15 km/h.
- Electro-hydraulic distributor for raising and lowering the brushes, controlled from the driver's cab.
- Hydraulic right/left brush adjustment for waste disposal.
- Mechanical oscillation on the right and on the left complies with the road conformity.
- Removable bearing carrier which ensures a quick release of the brush.

Technical characteristics

MODEL	TOWED HYDRAULIC 2 BRUSHES
<i>Brush length</i>	2000 mm
<i>Brush diameter</i>	600 mm
<i>Hub</i>	Metal
<i>Brush fibre type</i>	1st brush polyester 2nd brush mixed
<i>Right / left offset</i>	560 mm right(rear brush)
<i>Orientation</i>	+/- 25°
<i>Oscillation</i>	5°
<i>Brushing speed</i>	From 5 to 15 km/h
<i>Dimensions (L x W x H)</i>	5,26 x 2,19 x 1,36 m
<i>Weight (without options)</i>	1400 kg
<i>Coupling</i>	Fixed drawbar for fitting to commercial vehicles, vans, 4x4s, site machinery, etc.
<i>Drive</i>	Hydraulic through wheels or petrol power
<i>Wheels (Number: 2)</i>	175/80 R14C
<i>Travel speed</i>	25 km/h

Standard equipment

- Anti-projection guard.
- Height-adjustable jockey wheel.
- Hooking ball Ø 50 mm and Ø 68 mm ring.
- Mudguard.
- Spare wheel mounted on the sweeper.



TOWED 2 brushes + specific painting

	Price	Reference
MODEL		
TOWED 2 BRUSHES Hydraulic drive by the towing unit	38040.00	72097J
OPTIONS		
Hydraulic power dual-hydraulic pump with oil tank, shaft and 6-way electro valve	11935.00	70111B
Mixed brush ring (polypropylene/polyester) Ø 600 mm, value for 1 m	340.00	24F006
Polyester brush ring Ø 600 mm, value for 1 m	480.00	24F004



SUPERNET 2000 INDUS with option heat engine



SUPERNET 2000 INDUS with option heat engine



SUPERNET 2000 INDUS with option heat engine



Rabaud advantages

- Use for industries (timber, stationery, materials, glass ..), roadways, construction sites...
- Quick mounting on the forklift.
- Possibility to adapt a 5,25 kW / 7 HP heat engine for carriers with low flow.
- Mechanical right/left orientation +/- 20°.
- Polypropylene brush Ø 550 mm with long fibres Ø inner 127 mm / Ø outer 550 mm.
- 3 adjustable depth control wheels.

Technical characteristics

MODEL	SUPERNET 2000 INDUS.
<i>Brush length</i>	2000 mm
<i>Brush diameter (inner / outer)</i>	127 mm / 550 mm
<i>Brush fibre type</i>	Polypropylene
<i>Orientation</i>	+/- 20°
<i>Dimensions (L x W x H)</i>	1,54 x 2,28 x 0,71 m
<i>Weight</i>	200 kg
<i>Coupling</i>	Forklift by 2 sleeves 140 mm wide
<i>Oil flow</i>	15 L/min. mini. - 60 L/min. max.
<i>Maximum pressure</i>	200 bar
<i>Options</i>	Petrol heat engine 5,25 kW/7 HP, Ø 550 mm side brush

Standard equipment

- Forks.
- Hydraulic hoses with 2 male couplers 1/2".
- Mechanical angling +/- 20°.
- Control wheel.



Tilting setting

	Price	Reference
MODEL		
SUPERNET 2000 INDUS. Forks for forklift	2860.00	72042G
OPTIONS		
Polyester side brush Ø 550 mm with motor, hoses, 3-way valve	995.00	72004B
5.25 kW / 7 HP KOHLER petrol engine (3-year warranty) + pump + 10 L oil tank	1075.00	70184A
SPARE BRUSHES		
Side brush Ø 550 mm	140.00	055A25
Polypropylene brush Ø 550 mm value for 1 m	245.00	24F002



TURBONET 1500 AUTONOME + options :
watering & side brush



TURBONET 1500 AUTONOME + options :
watering & side brush



TURBONET 1500 AUTONOME + options :
watering & side brush



- Collecting sweeper without hydraulic connection through the forklift => fast coupling without getting out of the vehicle.
- Independent sweeper : the hydraulic drive is made by the rotation of the wheels on the ground.
- Inserted hydraulic motors in the metal brush hub for compact transport size and for engine protection.
- Collecting process is done by the top of the machine with an excellent collecting rate of 80 %.
- Box emptying with 2 hydraulic cylinders with actuation from the operating cab. Up to 4 cycles between 2 sweepings.
- Floating polypropylene brush Ø 530 mm with shape.
- Reinforced side mudflaps and frame for an intensive use.
- Swiveling rubber wheels to respect the swing radius.

Standard equipment

- Forks with locking system.
- 2 reinforced swiveling rubber wheels for the drive + 1 control rubber wheel, 360° swiveling.
- Compensation metal sheeting for the brush wear.

Technical characteristics

MODEL	TURBONET 1500 AUTONOME
<i>Brush length</i>	1500 mm
<i>Brush diameter</i>	530 mm
<i>Hub</i>	Metal
<i>Brush fibre type</i>	Chevron polypropylene
<i>Collecting box volume</i>	460 L
<i>Dimensions (L x W x H)</i>	1,93 x 1,72 x 1,03 m
<i>Weight</i>	671 kg
<i>Coupling</i>	Forklift forks
<i>Pressure</i>	120 bar min. - 200 bar max.
<i>Working speed</i>	5 km/h recommended



Collecting box emptying from the driver station

	Price	Reference
MODEL		
TURBONET 1500 AUTONOME For forklift	9225.00	72084H
OPTIONS		
Side broom Ø 700 mm with 3-way valve - In polyester	1615.00	72023E
Gravity watering on the main brush with 2 water tanks of 100 L - spraying line kit	1450.00	72085H
Pressure watering on side brush with 2 sprays	165.00	72097C
Specific painting	185.00	72009C
SPARE BRUSHES		
Chevron polypropylene brush Ø 530 mm - length 1500 mm	310.00	24F017
Side brush Ø 700 mm In polyester	175.00	055A10



Emptying of the TURBONET mounting on loader



TURBONET 2000 A with option side brush



TURBONET 2000 A with watering + hydraulic unit

- Adaptable on many carrier vehicles: tractor front or rear 3-point linkage, front loader, telescopic, backhoe loader, loader.
- Works in the driving direction.
- Collecting process is done by the top of the machine with an excellent collecting rate of 80 %.
- Emptying of the box by 2 hydraulic cylinders.
- Mixed brush (Polyester / Polypropylene) Ø 600 mm with long fibers.
- Reinforced side mudflaps and frame for an intensive use.
- Serial floating coupling to follow the road form.
- 4 swiveling depth control wheels 360°.
- Excellent driver visibility and ease of use.



Technical characteristics

MODELS	TURBONET 1500 A	TURBONET 2000 A	TURBONET 2300 A
<i>Brush length</i>	1500 mm	2000 mm	2300 mm
<i>Brush diameter (inner / outer)</i>	178 mm / 600 mm		
<i>Hub</i>	Metal		
<i>Brush fibre type</i>	Mixed (polypropylene/polyester)		
<i>Collecting box volume</i>	460 L	620 L	720 L
<i>Dimensions (L x W x H)</i>	1,92 x 1,72 x 1,01 m	1,92 x 2,22 x 1,01 m	1,92 x 2,52 x 1,01 m
<i>Weight with 1 hydraulic motor</i>	480 kg	569 kg	669 kg
<i>Weight with 2 hydraulic motors</i>	512 kg	600 kg	698 kg
<i>Coupling</i>	3-point tractor front and rear N°2, front loader, telescopic handler, backhoe loader...		
<i>Flow 1 hydraulic motor</i>	30 L/min. mini. - 60 L/min. max.		
<i>Flow 2 hydraulic motors</i>	61 L/min. mini. - 120 L/min. max.		
<i>Pressure</i>	120 bar min. - 200 bar max.		

Standard equipment

- 4 control solid rubber wheels swiveling 360°.
- Compensation metal sheeting for the brush wear.
- 2 hydraulic hoses with 2 ½" male valve couplings.

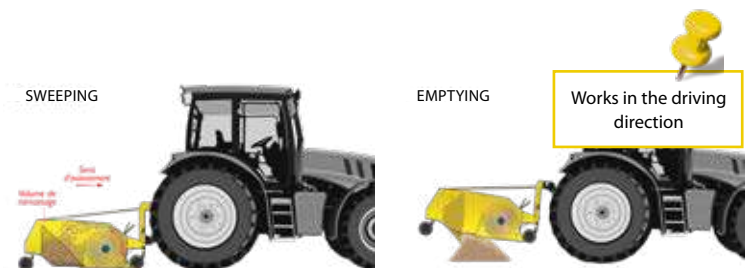

MODELS	Price	Reference	Price	Reference	Price	Reference
TURBONET with 1 HYDRAULIC motor • For carriers with oil flow < 60 L/min.	7980.00	72018E	8425.00	72016E	8835.00	72026F
TURBONET with 2 HYDRAULIC motor • For carriers with oil flow > 60 L/min.	9080.00	72019E	9455.00	72017E	9870.00	72027F
COUPLING HITCH > OBLIGATORY TO DETERMINE						
• 3-point farm tractor rear linkage (standard on 2300)	650.00	72020E	650.00	72020E	1095.00	72030F
• 3-point front tractor linkage	745.00	72021E	745.00	72021E	745.00	72021E
• Telescopic, backhoe loader, loader, compact loader	1225.00	75936F	1225.00	75936F	1225.00	75936F
• Forks (a pair)	1630.00	72022E	1630.00	72022E	1630.00	72022E
• Front loader with load transfer (contact us)	2215.00	72029F	2215.00	72029F	2215.00	72029F
• Mini-excavator with 8-holes plate (Quick-fit coupling to be determined, see pages 230-233)	1270.00	75937F	1270.00	75937F	1270.00	75937F
• MECALAC CONNECT or ACTIV LOCK fastener	1240.00	75938F	1240.00	75938F	1240.00	75938F
OPTIONS for all MODELS						
Hydraulic unit and PTO 540 rpm with oil and shaft valve dual-acting, bank select with oil cooling system	4065.00	70160A	4065.00	70160A	4065.00	70160A
Thermal power station 13.25 kW / 18 HP BRIGGS & STRATTON petrol engine (3-year warranty) with cooler*	5895.00	70162A	5895.00	70162A	5895.00	70162A
Side broom Ø 700 mm with 3-way valve	In polyester	1615.00	72023E	1615.00	72023E	1615.00
	In steel/rilsan	1675.00	72051G	1675.00	72051G	1675.00
	In flat steel (oil cooler is advised)	1820.00	72069H	1820.00	72069H	1820.00
Claws to clean gutters (side brush is necessary)	425.00	72059F	425.00	72059F	425.00	72059F
Construction warning signs kit 12 V with reflecting stripes, 2 luminous tubes, LED lights Requires a power supply	470.00	72062F	470.00	72062F	470.00	72062F
12 Volts lighting kit*** (stand for licence plate with lighting, 2 near lights)	625.00	72029G	625.00	72029G	625.00	72029G
Support for handled tools : shovel, rake... (max. 2)	70.00	71836C	70.00	71836C	70.00	71836C
Specific painting	185.00	72009C	185.00	72009C	185.00	72009C
EPOXY painting	430.00	72033G	430.00	72033G	430.00	72033G
WATERING (except front loader with load transfer and forklift) with 2 x 100-litre tanks mounted on the sweeper - Spray bar kit**						
Pressure watering (kit electrical pump 12 V***)	2010.00	72047D	2010.00	72049D	2010.00	72042F
Pressure watering on side brush with 2 sprays	165.00	72097C	165.00	72097C	165.00	72097C
SPECIFIC WATERING SYSTEMS (for front loader with load transfer) with 300 L tank kit mounted on the tractor's rear 3-point linkage - Spray bar kit**						
Pressure watering (kit electrical pump 12 V***)	2490.00	72077F	2450.00	72078F	2430.00	72079F
Pressure watering on side brush with 2 sprays	165.00	72097C	165.00	72097C	165.00	72097C
SPECIFIC WATERING (for forklift elevator adaptation)						
Pressure watering (kit electrical pump 12 V***)	2365.00	72085B	2365.00	72011E	2410.00	72045F
SPARE BRUSHES						
Mixed brush ring (polyester/polypropylene) Ø 600 mm, value for 1 m	340.00	24F006	340.00	24F006	340.00	24F006
Side brush Ø 700 mm	In polyester	175.00	055A10	175.00	055A10	175.00
	steel/rilsan	290.00	055A42	290.00	055A42	290.00
	Flat steel	145.00	055A60	145.00	055A60	145.00

* No compatibility with front loader hitch

** 6-spray TURBONET 1500A, 8-spray TURBONET 2000A, 10-spray TURBONET 2300A

*** Needs electrical power



URBANET 1500 G in operation



URBANET 1500 G



URBANET 1500 G - Emptying



- **NEW** : Front brush to pick up all types of bulky waste (bottles, stones, plants, dust, etc.).
- Sweeping width 1.50 or 2 m depending on model.
- Emptying height: 2.10 m thanks to the hydraulic lifting arm.
- Large-volume collecting box with fill control flap.
- Designed for narrow streets, alleyways, cycle paths... in your town or city.
- Hydraulic sweeper up and down to switch between transport to sweeping position.
- Suitable on low-power tractors (25 HP).
- Tractor pump drive with 3-way dual acting valve (for sweeping, lifting and tipping) or optional 540 rpm PTO with 3-way dual acting.
- Pressure watering option with 300-litre water tanks.
- Hydraulically adjustable offset hitch option (25 cm to the right / 25 cm to the left)
- Ø 700 mm side brush in polyester, rilsan polyamide or flat steel for mechanical weeding (optional).
- Mixed brush (polyester and polypropylene) Ø 600 mm. Adjustable in height depending on its wear.
- ORGANIC oil Panolin® (hydraulic unit with) : 15 000 hours lifetime.
- 2 oversized rear wheels + 1 depth control wheel.

Technical characteristics

MODELS	URBANET 1500 G	URBANET 2000 G
Brush length	1500 mm	2000 mm
Brush diameter	600 mm	
Brush fibre type	Mixed (polypropylene + polyester)	
Collecting box volume	1000 L	1340 litres
Emptying height	2,10 m	
Dimensions (L x W x H)	3,00 x 1,85 x 1,15 m	3,00 x 2,35 x 1,15 m
Weight (empty)	950 kg without option 1200 kg all options included	1085 kg without option
Ceramic pistons pump	25 to 40 l/min max.	
Maximum pressure	200 bar	
Coupling	3-point rear Adjustable drawbar with drawbar eye	
Tractor power	From 25 HP	From 40 HP
Drive	3 dual-acting lines tractor's pump or PTO 540 rpm, hydraulic tank 40 L	Tractor hydraulic pump with 3 double-acting lines or PTO 540 rpm, 70-liter tank

Standard equipment

- Mixed brush diameter 600 mm.
- 6 hydraulic hoses with ½" male coupler (sweeping, lifting and tipping).
- Road signs (plate + lighting).
- Collecting box 1000 L or 1340 L- Emptying height up to 2.10 m.



NEW FRONT BRUSH
PATENTED SYSTEM



URBANET 1500 G with high-visibility painting



Option watering on side brush



Support for handled tools

MODELS				Price	Reference
URBANET 1500 G				15645.00	72079J
URBANET 2000 G				18165.00	72087J
OPTIONS		1500 G	2000 G		
Hydraulic unit PTO 540 rpm with hydraulic outlet and PANOLIN® ORGANIC oil*	3-way dual-acting valve (for sweeping, lifting and tipping)	●	●	2760.00	70107B
	3-way dual-acting valve (for sweeping, lifting and tipping) + oil cooler	●	●	3500.00	70106B
3-element hydraulic distributor D.E.		●	●	745.00	72045H
Electro-hydraulic control with radio-control		●	●	2010.00	72075H
Side broom Ø 700 mm with 3-way valve	In polyester	●	●	1615.00	72082J
	In steel/rilsan	●	●	1675.00	72083J
	In flat steel (oil cooler is advised)	●	●	1820.00	72084J
Watering	Pressure (12 V pump kit - needs electrical power) - 2 tanks of 150 L	●	●	2020.00	72080J
		●	●	2020.00	72092J
	Side brush	●	●	165.00	72035H
Hydraulically adjustable offset hitch (25 cm to the right / 25 cm to the left)		●	●	840.00	72090J
Revolving light with LED		●	●	255.00	72067H
12 V lighting kit - warning triangle		●	●	710.00	72028H
Support for handled tools : shovel, rake... (max. 2)		●	●	70.00	71836C
Support for garbage bag		●	●	260.00	72050H
High-visibility painting		●	●	410.00	72014J
SPARE BRUSHES					
Polypropylene/polyester brush Ø 600 mm - value for 1 m		●	●	330.00	24F006
Front brush collector		●		Contact us	
			●	Contact us	
Side brush Ø 700 mm	In polyester	●	●	175.00	055A10
	steel/rilsan	●	●	290.00	055A42
	Flat steel	●	●	145.00	055A60

*hydraulic pump flange-mounted on the PTO, requiring no transmission



URBANET 1500 G vs URBANET 2000 G



Biodegradable Oil



Reduced carbon footprint



Drain up to 15000 hours if respect of the recommendations



Fuel economy



GB 2100 - Discharging gravels



GB 2100



GB 2100 - Sweeping

- More versatility: Can be used for material handling and sweeping/collecting.
- Liftable brush, allowing the bucket to be used for roughing or loading
- Backward sweeping for a neat finish.
- 5 sweeping widths :
1,20 m - 1,50 m - 1,80 m - 2,10 m or 2,40 m
- Adaptation on telescopic, backhoe loader, loader...
- Longer brush life: brush mechanically adjustable for wear.
- Mixed brush (polypropylene / polyester), Ø 600 mm.
- Extra strength: 16 mm thick cutting blade and bucket with reinforcing counter-fold.
- Emptying of the bucket by breaking it out thanks to the hydraulic cylinder.



Dust collection with the bucket

Technical characteristics

MODELS	GB 1200	GB 1500	GB 1800	GB 2100	GB 2400
Coupling	Loader, Telescopic, Backhoe loader...				
Brush length	1200 mm	1500 mm	1800 mm	2100 mm	2400 mm
Diameter (inner / outer)	178 mm / 600 mm				
Hub	Metal				
Brush fibre type	Mixed (polypropylene/polyester)				
Dimensions (L x W x H)	1,17 x 1,32 x 0,91 m	1,23 x 1,62 x 0,91 m	1,23 x 1,97 x 0,91 m	1,23 x 2,27 x 0,91 m	1,23 x 2,57 x 0,91 m
Weight (1 motor / 2 motors)	306 kg	511 kg	565 / 590 kg	590 / 643 kg	672 / 695 kg
Flow 1 hydraulic motor	20 L/min. mini. - 60 L/min. max.				
Flow 2 hydraulic motor	-	61 L/min. mini. - 120 L/min. max			
Pressure	200 bar				
Collecting box emptying	By lifting the brush using a hydraulic cylinder (dual-acting)				
Collecting box volume	410 L	510 L	610 L	710 L	810 L

Standard equipment

- Collecting box : 410, 510, 610, 710 and 810 L according to the model.
- Mixed brush (polypropylene / polyester), Ø 600 mm.
- 2 hydraulic hoses with 2 ½" male valve couplings.



With coupling to determine :
here for telescopic



Mounting on articulated loader

	Price	Reference
MODELS		
GB 1200 • 1 hydraulic motor for carriers with oil flow < 60 L/min.	4740.00	72066J
GB 1500 • 1 hydraulic motor for carriers with oil flow < 60 L/min.	5145.00	72070G
GB 1800 • 1 hydraulic motor for carriers with oil flow < 60 L/min.	5575.00	72071G
• 2 hydraulic motor for carriers with oil flow > 60 L/min.	6785.00	72072G
GB 2100 • 1 hydraulic motor for carriers with oil flow < 60 L/min.	6075.00	72073G
• 2 hydraulic motor for carriers with oil flow > 60 L/min.	7280.00	72074G
GB 2400 • 1 hydraulic motor for carriers with oil flow < 60 L/min.	6775.00	72075G
• 2 hydraulic motor for carriers with oil flow > 60 L/min.	7915.00	72076G
COUPLING HITCH > OBLIGATORY TO DETERMINE		
• Backhoe loader, loader, compact loader, skid steer loader, farm loader	595.00	76037F
• Excavator coupling hitch with 8-hole plate	680.00	76039F
• MECALAC CONNECT or ACTIV LOCK fastener	890.00	76040F
OPTION		
Kit to hold the brush when emptying – for telescopic type Merlo, Bobcat, Kubota skidsteer.	450.00	72026G
50 l/min hydraulic flow divider (maximum oil flow 150 l/min) with 190 bar pressure relief valve. Caution : single direction rotation for brush	525.00	72028K
SPARE BRUSH		
Mixed brush ring (polypropylene/polyester) Ø 600 mm, value for 1 m	340.00	24F006



OPERATION :

- Forward -> collecting
Backward -> sweeping



HERBIONET - T



HERBIONET - T



HERBIONET - T

- Weeding brush suitable for all tractor configurations :
 - Double hitch for right or left-hand operation.
 - Adaptable to either front or rear of tractor.
 - N°0, N°1 or N°2 tractor 3-point hitch and triangle coupling.
- 4 brush models, Ø 500 or 750 mm, in flat or steel strands.
- Brushes adapted to the surface or type of roadwork to be weeded.
- Mechanical tilting (hydraulic in option).
- Hydraulic offset with telescopic arm : 0.90 m.
- Depth control wheel adjustable in height with spacers.



Rabaud
advantages



Brush type

Technical characteristics

MODELS	HERBIONET - T PH	HERBIONET - T CH
Brush diameter	Ø 500 or 750 mm	
Brush fibre type	Flat steel or steel strands	
Dimensions (L x W x H)	0,75 x 2,00 x 1,00 m	
Weight (without hydraulic unit)	145 kg	
Coupling	For tractor from 15 HP - Cat. 0, 1 & 2 or telescopic, loader	
Oil flow	From 20 L/min. to 60 L/min. max.	
Pressure	200 bar max.	



Offset movement on HERBIONET - T



Standard equipment

- Hydraulic offset with telescopic arm : 0.90 m.
- Mechanical tilting of the brush, adjustable with a screw (hydraulic in option).
- 4 hydraulic hoses and 4 ½" male valve couplers (sweep and offset).
- Depth control wheel adjustable in height with spacers.
- 3-point linkage for tractor N°0, 1 and 2 or triangle or telescopic handler, skid-steer loader.



MODELS		Price	Reference	
HERBIONET - T For a 3-point linkage adaptation – Without brush • PH : drive through tractor pump				2915.00
HERBIONET - T • CH : drive by hydraulic unit, delivered with oil PTO 540 rpm*	Rear 3-point coupling	3905.00	72008J	
	Front 3-point coupling	Hydraulic unit at the front	3845.00	72010J
		Hydraulic unit at the rear	4550.00	72009J
VALVES > OBLIGATORY TO DETERMINE		PH	CH	
• 3-way valve* (only for rear-mounted brush)		●	●	
• 8-way valve with radio control - up to 3 hydraulic functions (without servo-controlled movements)		●		
• Electric valve with radio control - up to 3 hydraulic functions (with servo-controlled movements)		●	●	
BRUSHES > OBLIGATORY TO DETERMINE				
Ø 500 mm steel brush + support	flat steel	360.00	72082G	
	steel wire strands	440.00	72083G	
Ø 750 mm steel brush + support	flat steel	615.00	72084G	
	steel wire strands	665.00	72085G	
OPTIONS				
Anti-projection guard	with chains	490.00	72068H	
	with rubber	190.00	72086G	
Hydraulic tilting cylinder on the brush (if drive through tractor pump, 1 more dual-acting valve needed)		260.00	72080G	
Triangle coupling : Municipal 0/1/2/3		320.00	72072H	
Mixed coupling for telescopic loader		755.00	76418A	
Supplementary coupling kit + axles & pins		220.00	72088G	
SPARE BRUSHES				
Ø 500 mm steel brush	flat steel	260.00	24G004	
	steel wire strands	335.00	24G010	
Ø 750 mm steel brush	flat steel	470.00	24G005	
	steel wire strands	535.00	24G008	

* hydraulic pump flange-mounted on the PTO, requiring no transmission
 * not required on tractors fitted with 3 double-acting valves
 The ● means compatibility of options with different models.

✓ OPTIONS



Remote radiocontrol



Mudflap with rubber



Mudflap with chains



Hydraulic unit



HERBIONET BE with brush Ø 750 mm



HERBIONET BE with brush Ø 750 mm



Rabaud
advantages

- Mechanical weeding brush adaptable on mower arms.
- Brush diameters adapted to alternative weed control. Cleaning of all types of road structures : islands, under guardrails, concrete culverts, bridges, etc.
- 4 brush models : Ø 500 / 750 / 1000 or 1200 mm in flat or strand steel.
- Quick assembly / disassembly of the brushes (no tools required).
- Front/rear tilting + speed variator (electric control moved to the cabin) and left/right tilting (tilting of the brush on the arm mower).
- High-torque hydraulic motor.
- In-cab control box for motion control + speed variator.
- Height-adjustable central stem.
- Suspension parallelogram to keep the brush pushed on the ground.
- 3 double-acting hydraulic cylinders :
 - Right/left orientation for transport/work deployment,
 - Hydraulic front/rear brush tilting,
 - Hydraulic parallelogram for constant ground pressure.

Technical characteristics

MODEL	HERBIONET BE
<i>Brush diameter</i>	500, 750, 1000 and 1200 mm
<i>Brush fibre type</i>	Flat steel or steel wire strands
<i>Brush speed</i>	Adjustable from 0 to 160 rpm
<i>Coupling</i>	Any mower arm > 53 HP
<i>Oil flow</i>	60 l/min mini. - 125 l/min maxi.
<i>Pressure</i>	210 bar max.
<i>Weight</i>	290 to 330 kg



Standard equipment

- High-torque hydraulic motor.
- 4 hydraulic functions:
 - Right/left orientation
 - Rear/front tilting of the brush,
 - Parallelogram for constant brush contact with the floor
 - Brush adjustable speed + double direction for rotation.
- Speed variator + control box in the cabin.
- Fixing according to your arm mower (please precise brand + model).



Brush types

		Price	Reference
MODEL			
HERBIONET BE - For adaptation on mower arm		10175.00	72037H
COUPLING HITCH > OBLIGATORY TO DETERMINE			
• Normal coupling for mower arm		390.00	76953A
• Half automatic coupling for Noremat mower arm		1440.00	72057G
BRUSHES > OBLIGATORY TO DETERMINE			
Ø 500 mm steel brush + support	Flat steel with fixing plate	380.00	72058G
	Steel wire strand with fixing plate	470.00	72038H
Ø 750 mm steel brush + support	Flat steel with fixing plate	745.00	72059G
	Steel wire strand with fixing plate	805.00	72039H
Ø 1000 mm flat steel brush - 4 brush units - with fixing plate		1030.00	72060G
Ø 1200 mm flat steel brush with fixing plate - 5 brush units - with fixing plate		1220.00	72061G
OPTIONS			
Anti-projection flap		355.00	72031H
Storage trolley		1015.00	72005H
SPARE BRUSHES			
Ø 500 mm steel brush	flat steel	260.00	24G004
	steel wire strands	335.00	24G010
Ø 750 mm steel brush	flat steel	470.00	24G005
	steel wire strands	535.00	24G008
Unit for flat steel wire brush Ø 1000 and 1200 mm - one unit		150.00	24G007



HERBIONET BE



HERBIONET PE



HERBIONET PE with brush Ø 500 mm

- Mechanical weeding brush for excavators from 4 to 12 tons, whatever the coupling.
- Brush diameters adapted to alternative weed control. Cleaning of all types of road structures : islands, under guardrails, concrete culverts, bridges, etc.
- 3 brush models, Ø 500, 750 mm or 1000 mm, in flat or strand steel.
- Quick assembly / disassembly of the brushes (no tools required).
- Optional: mechanical or hydraulic brush tilting.
- High-torque hydraulic motor protected by a casing.

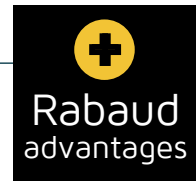

Technical characteristics

MODEL	HERBIONET PE
Brush diameter	500, 750 and 1000 mm
Brush fibre type	Flat steel or steel wire strands
Brush speed	250 rpm max.
Coupling	Excavator from 4 to 12 Tons
Oil flow	60 L/min - 125 L/ max.
Pressure	250 bar max.
Weight	110 kg

BRUSHES				
	500	750	1000	1200
A	500	750	1000	1200
B	153	278	403	503
C	212	212	240	240



Brush types

		Price	Reference
MODEL			
HERBIONET PE - For adaptation on excavator from 4 to 12 Tons		3655.00	72036H
COUPLING HITCH > OBLIGATORY TO DETERMINE			
• Excavator with automatic coupling hitch		See page 230-233	
• STANDARD plate 8 holes without bolts for your own adaptation		86.00	70366703L
BRUSHES > OBLIGATORY TO DETERMINE			
Ø 500 mm steel brush + support	Flat steel with fixing plate	380.00	72058G
	Steel wire strand with fixing plate	475.00	72038H
Ø 750 mm steel brush + support	Flat steel with fixing plate	745.00	72059G
	Steel wire strand with fixing plate	805.00	72039H
Ø 1000 mm flat steel brush - 4 brush units - with fixing plate		1030.00	72060G
OPTIONS			
Tilting	Mechanical tilting of the brush with pushing bar	1020.00	72040H
	Hydraulic tilting – Needs one supplementary 1-way dual acting valve	1270.00	72041H
6-way hydraulic valve + lead wire extension 12 m long, 12V		860.00	72043H
SPARE BRUSHES			
Ø 500 mm steel brush	flat steel	260.00	24G004
	steel wire strands	335.00	24G010
Ø 750 mm steel brush	flat steel	470.00	24G005
	steel wire strands	535.00	24G008
Unit for flat steel wire brush Ø 1000 and 1200 mm - one unit		150.00	24G007



HERBIONET PE with option hydraulic tilting





NHP 600 with high-pressure lance



NHP 600



NHP 600 in storage

+
Rabaud
advantages

- Tractor 3-point hitch. No electrical connection or engine.
- Weatherproof and corrosion-resistant 600-litre polyethylene tank.
- High-pressure pump with a flow of 13 l/min for high cleaning power and low water consumption.
- Easy-access filter to protect the pump from impurities and extend its life.
- Drain system for draining and winterizing the washer.
- Long lance length for greater working comfort.
- 15-metre hose to get as close as possible to cleaning areas.
- Mounted on a frame with 4 swivel wheels, 2 of which have brakes for easy transfer.

Technical characteristics

MODEL	NHP 600
<i>Tank capacity</i>	600 L
<i>Coupling</i>	N°1 and 2 front/rear 3-point linkage
<i>Drive</i>	540 rpm PTO - 2 ways of rotation
<i>Minimum oil flow</i>	13 l/min
<i>Working pressure</i>	170 bar
<i>Weight (without water)</i>	160 kg

Standard equipment

- 600-litre polyethylene water tank.
- Rewinder with 15 m hose.
- Lance with handle.
- Filter to protect the pump.
- 4 rotating wheels, 2 of which have brakes.



Kit watering

✓ OPTIONS



Spray kit with 20 m automatic hose reel and 12 V electric pump



Detergent suction kit + spray kit with 20 m automatic hose reel and 12 V electric pump

	Price	Reference
MODEL		
NHP 600 - for 3-point hitch N°1	4130.00	73214A
OPTIONS		
Spray kit with 20 m automatic hose reel and 12 V electric pump	730.00	73215A
Detergent suction kit + spray kit with 20 m automatic hose reel and 12 V electric pump	1105.00	73216A
Drain unblocker + Cleaning ramp	115.00	73218A
24-litre storage box	205.00	73217A
Kit 3-point hitch front N°1 or N°2	195.00	73220A



WINDY 491 ME



WINDY 491 ME



WINDY 660 ME

- 2 models on road trailer with jockey wheel, light ramp, ball coupling.
- Powered by a 14 HP or 22 HP petrol heat engine, with electric battery start. Engine GUARANTEED 3 years.
- Big diameter turbine (490 mm on WINDY 491 and 660 mm on WINDY 660) for more air flow. Turbine casing with 5-year guarantee.
- Side shifted rotor to avoid accumulation and therefore early stuffing, with easy removable blades.
- More security : the turbine is stopped in less than 10 sec. thanks to the hydraulic brake (WINDY 491).
- 5 m sleeve mounted on swiveling support with handle and wheels.
- Fixed outlet blower on WINDY 491 and 360° swivel on WINDY 660. Folding discharge chute for transport.
- Approved road trailer weighing less than 750 kg. Conventional driving licence is sufficient.
- Discover in option the CASING KIT to keep all the collected waste in your tipper.

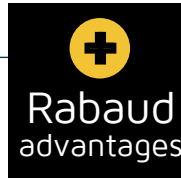

5 YEAR **VOLUTE WARRANTY**

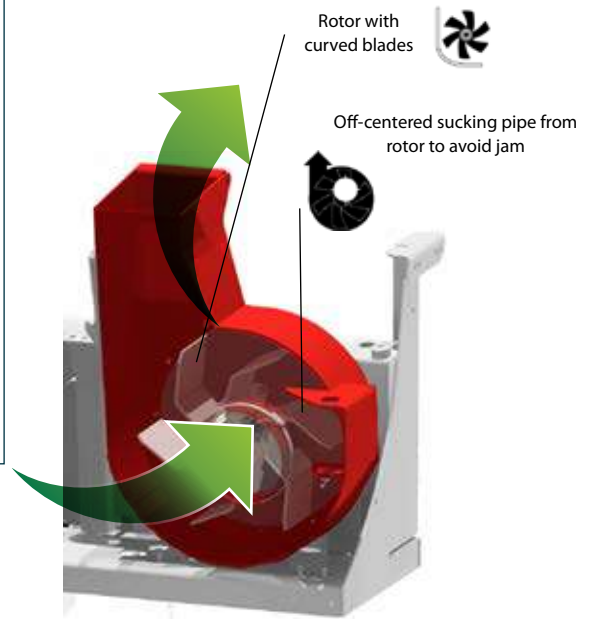

Technical characteristics

MODELS	WINDY 491 ME	WINDY 660 ME
Turbine diameter	490 mm	660 mm
Rotor diameter	402 mm	460 mm
Blades number	6 removable blades	
Sleeve	5 m, Ø 200 mm	
Discharge chute	Fixed	Mounted on folding ball bearing and 360° swivel with notched handle and chain-adjustable cap
Dimensions (L x W x H)	2,46 x 1,46 x 1,66 m	3,70 x 1,44 x 1,65 m
Weight	330 kg	440 kg
Coupling	Road trailer with fixed drawbar	Road trailer with articulated drawbar
Drive/Motor power	BRIGGS & STRATTON - Petrol heat engine 10.5 kW / 14 HP 3-year warranty	HONDA - Petrol heat engine 16.5 kW / 22 HP 3-year warranty



WINDY 660 ME - Transport

Standard equipment

- Large-diameter turbine with 6 removable blades.
- Turbine volute (5-year warranty).
- 5 m sucking sleeve, Ø 200 mm.
- Road trailer with jockey wheel, light ramp, ball coupling.



			Price	Reference
MODELS				
WINDY 491 ME (Road trailer)			8910.00	73936A
• Petrol heat engine BRIGGS & STRATTON 10.5 kW / 14 HP (3-year WARRANTY) - Electric start				
WINDY 660 ME (Road trailer)			14255.00	73949A
• Petrol heat engine HONDA 16,5 kW / 22 HP (3-year WARRANTY) - Electric starter				
OPTIONS	WINDY 491 ME	WINDY 660 ME		
Spare wheel + support	•		300.00	70028C
		•	295.00	73944A
Flashing stripes with stand	•	•	99.00	73913A
Tool chest	•	Serial	350.00	73938A
Support for handled tools : shovel, rake... (max. 2)	•	•	75.00	71836C
Parking brake		•	535.00	71874C
Presence sensor of the suction sleeve		•	280.00	73943A
	•		280.00	73941A
Tachometer on internal combustion engine (rev counter with hour meter)	•	•	190.00	99151A
SPARE PARTS				
Blade - unit	•		33.00	739204
		•	32.00	739180
Sucking sleeve Ø 200 mm - Value for 1 m - Delivered in 5 m or 10 m	•	•	90.00	32A131

The ● means compatibility of options with different models.

	Price	Reference
CASING KIT FOR DUMP TRUCK		
CASING KIT FOR DUMP TRUCK - 3.5 T max. vehicle	1955.00	73914A
Tarpaulin made of PVC 350 g/m ² - Tipping length min. 2.55 m and max. 4.25 m - Tipping width mini. 1.60 m and max. 2.45 m - Height of the kit : 1.67 m - To use with vacuum cleaner., wood shredder...		

ZOOM : CASING KIT FOR DUMP TRUCK



Casing kit for dump truck



Less than one hour for mounting



Casing kit door opening for unloading



WINDY 286 RL - Manual installation



WINDY 286 RL



WINDY 286 RL

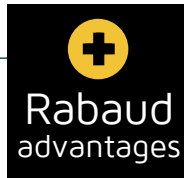

- Quickly fitted to the side panel of a tipper truck thanks to two ergonomic handles.
- Powered by a 5.8 hp HONDA internal combustion engine. 3-year engine warranty.
- Big diameter turbine for more air flow. Turbine casing 5-year WARRANTY.
- Quick turbine stop for greater safety.
- Eccentric rotor to avoid blockages in the axis, with 4 removable blades in 300 HB.
- 5 m suction hose, Ø 160 or 200 mm, with aluminium handle and earth wheel.
- Adjustable cap at the end of the chute to fill the skip evenly.
- No maintenance for the bearing: already lubricated for life.
- Discover in option the CASING KIT to keep all the collected waste in your tipper.

Technical characteristics

MODEL	WINDY 286 RL
<i>Turbine diameter</i>	305 mm
<i>Rotor diameter</i>	286 mm
<i>Blades number</i>	4 removable blades
<i>Sleeve</i>	5 m, Ø 200 mm
<i>Dimensions (L x W x H)</i>	0,80 x 0,58 x 0,83 m
<i>Weight</i>	60 kg
<i>Coupling</i>	Side panel
<i>Drive Motor power</i>	Petrol heat engine HONDA 4,3 kW / 5,8 HP With rope starter 3-year warranty

		Price	Reference
MODELS			
WINDY 286 RL • 4,3 kW / 5,8 HP HONDA petrol engine (3-year GUARANTEE) - Starter motor - Manual start	Ø 160 mm suction hose	2890.00	73954A
	Ø 200 mm suction hose	2990.00	73953A
OPTIONS			
Tachometer on internal combustion engine (rev counter with hour meter)		207.00	99151A
SPARE PARTS			
Blade - unit		27.50	739211
Sucking sleeve Ø 200 mm - Value for 1 m - Delivered in 5 m or 10 m		100.40	32A131



WINDY 491 RE - Hydraulic installation



WINDY 491 RE



WINDY 491 RE



Rabaud advantages

- The WINDY 491 RE hoover can be fitted quickly to the side panel, and can be lifted by a single person, thanks to the integrated hydraulic lifting transport trolley = Reduced risk of RSI (Musculoskeletal Disorders) for the user, no effort required.
- Driven by internal combustion engine.
- Big diameter turbine for more air flow. Turbine casing 5-year WARRANTY.
- Safety: Turbine stops in less than 10 seconds thanks to the hydraulic brake.
- Side shifted rotor to avoid accumulation and therefore early stuffing, with easy removable blades.
- 5 m sleeve mounted on swiveling support with handle and wheels.
- Adjustable chute inclination to direct sprays into the hopper.
- No maintenance for the bearing: already lubricated for life.
- Discover in option the CASING KIT to keep all the collected waste in your tipper.

Technical characteristics

MODEL	WINDY 491 RE
<i>Turbine diameter</i>	490 mm
<i>Rotor diameter</i>	402 mm
<i>Blades number</i>	6 removable blades
<i>Sleeve</i>	5 m, Ø 200 mm
<i>Dimensions (L x W x H)</i>	1,05 x 1,75 x 1,78 m
<i>Weight</i>	260 kg
<i>Coupling</i>	Side panel (1.20 m to 1.70 m height Thickness from 15 to 80 mm)
<i>Drive Motor power</i>	Petrol heat engine BRIGGS & STRATTON 10.5 kW / 14 HP With electric starter 3-year warranty

Standard equipment

- Large diameter turbine with removable blades.
- Turbine volute (5-year warranty).
- Volute in CREUSABRO 8000 and blades in Hardox 300.
- 5 m sucking sleeve, Ø 200 mm.
- Transport trolley integrated on the WINDY 491 RE. With 2 braked swivel wheels and 2 fixed wheels, self-locking system on the side panel.

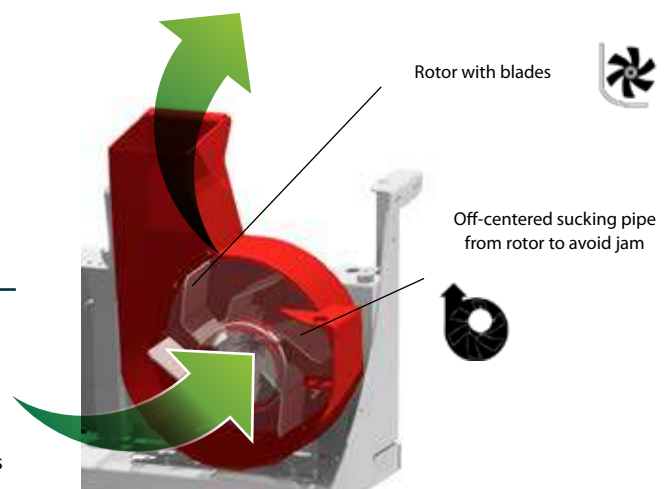

5 YEAR **VOLUTE WARRANTY**



	Price	Reference
MODELS		
WINDY 491 RE • Petrol heat engine BRIGGS & STRATTON 10.5 kW / 14 HP (3-year WARRANTY) - Electric start - Self-locking system on tailgate	7590.00	73934A
OPTIONS		
Road signs kit	270.00	73933A
Mounting on sidebar with banging doors - (consult us)	485.00	73935A
Presence sensor of the suction sleeve	280.00	73941A
Tachometer on internal combustion engine (rev counter with hour meter)	190.00	99151A
SPARE PARTS		
Blade - unit	33.00	739204
Sucking sleeve Ø 200 mm - Value for 1 m - Delivered in 5 m or 10 m	92.00	32A131



Hydraulic set-up at the rear of the truck, only 1 operator needed



	Price	Reference
CASING KIT FOR DUMP TRUCK		
CASING KIT FOR DUMP TRUCK - 3.5 T max. vehicle Tarpaulin made of PVC 350 g/m ² - Tipping length min. 2.55 m and max. 4.25 m - Tipping width mini. 1.60 m and max. 2.45 m - Height of the kit : 1.67 m - To use with vacuum cleaner, wood shredder...	1955.00	73914A

ZOOM : CASING KIT FOR DUMP TRUCK



Casing kit for dump truck



Less than one hour for mounting



Casing kit door opening for unloading



SNOOWNET 2500



SNOOWNET 2500



SNOOWNET 2500



Rabaud
advantages

- A range of 3 models : 2 m, 2.50 m or 3 m width.
- Working speed up to 40 km/h.
- Extremely rounded profile with a high density polyethylene protection to easily remove the snow.
- Scraping rubber : thickness 40 mm, Height 250 mm - Hardness 80 Shores.
- Anti-splash flap to avoid snow splashes on signalling (headlights...), casings, engines...
- Hydraulic rotation +/- 28° cylinder with safety relief valve.
- Hitch oscillates +/- 8° to follow road contours.
- Epoxy painting with stainless-steel bolting.
- Lightening kit with LUMIFOG and led lights for a longer life.

Technical characteristics

MODELS	SNOOWNET 2000	SNOOWNET 2500	SNOOWNET 3000
<i>Blade height</i>	0,84 m (0.72 m snow-clearing)		
<i>Snow clearance width at 28°</i>	1,73 m	2,17 m	2,60 m
<i>Oscillation</i>	+/- 8°		
<i>Orientation</i>	+/- 28°		
<i>Dimensions (L x W x H)</i>	1,26 x 2,25 x 1,68 m	1,26 x 2,75 x 1,68 m	1,26 x 3,25 x 1,68 m
<i>Weight (without the tyres) 3-point version</i>	290 kg	330 kg	365 kg
<i>Coupling</i>	3-point front tractor N°2 equipped with floating hitchor hitch with 1 DE + R -> 50 HP, telescopic handler and loader		
<i>Power max</i>	150 HP		
<i>Supply</i>	2 hydraulic hoses with 2 ½" male couplers + 1 elec. socket 3-pin		

Standard equipment

- High density polyethylene protection, 10 mm thick with scraping rubber 40 mm thick, 250 mm high, 80 shores hardness and mudguard.
- Signaling kit.
- Hydraulic rotation +/- 28° cylinder with safety relief valve.
- Dual-acting valve plug with 2 hoses, 2 male ½ couplers + 3-pin plug.
- Stand for storage.



Option depth control wheels



Option coupling hitch for other carrier (telescopic, front loader, ...)



Option coupling hitch for other carrier (telescopic, front loader, ...)



Snow plough
SNOWNET 3000



Snow plough
SNOWNET 2500

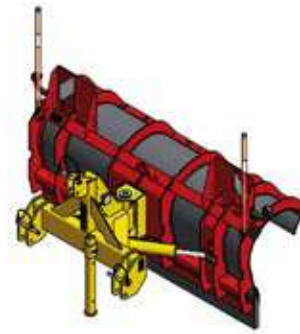

Snow plough
SNOWNET 2000

	<i>Price</i>	<i>Reference</i>	
MODELS			
SNOWNET 2000 : 2000 mm wide	4600.00	71109A	
SNOWNET 2500 : 2500 mm wide	4915.00	71110A	
SNOWNET 3000 : 3000 mm wide	5500.00	71111A	
COUPLING HITCH > OBLIGATORY TO DETERMINE			
• 3-point front tractor linkage	870.00	76408A	
• Telescopic, Loader	1425.00	76409A	
• DIN / SETRA plate with a 2nd cylinder for tilting	4490.00	76419A	
OPTIONS			
2 depth control solid-rubber wheels Ø 25 cm – width 80 mm – greaser – Crank adjusting	1010.00	71105A	
Second hydraulic cylinder for tilting	405.00	71108A	
Safety valve on cylinder for open center circuit (Merlot, Bobcat, Fdi-sambron, Kubota skidsteer...)	157.00	72105A	
12-volt front light kit - Tractor mounted	730.00	71106A	
Interface linkage for another carrier on SNOWNET 3-point hitch – Maximum weight 5 Tons (Telescopic..)	620.00	76406A	
SPARE PARTS			
Snow blade - 40 mm thick - 250 mm High - 80 shore	2,00 m long	310.00	19B049
	2.50 m long	370.00	19B046
	3.00 m long	410.00	19B050



Sweeper - Brush - Vacuum cleaner
Weeder - Salt spreader - Blade



Bull blade on loader



STANDARD



STANDARD 2.50 m with side flaps option

Technical characteristics

MODELS	LIGHT 1,50 m	LIGHT 2,00 m	STANDARD 2,00 m	STANDARD 2,50 m	BULL 2,00 m	BULL 2,50 m
Coupling	3-point linkage n°1 and 1N		3-point linkage n°1 and 2		According to carrier	
Blade width	1,50 m	2,00 m		2,50 m	2,00 m	2,50 m
Tractor power	max. 50 HP			70 up to 90 HP		
Total weight (without option)	168 kg	189 kg	460 kg	508 kg	407 kg	438 kg
Height	0,43 m		0,50 m			
Ø swivelling axle	70 mm		80 mm			
Blade rotation	360°		+/- 45° (mechanical)			
Offset	0°		20° right / 29° left (mechanical)		0°	
Tilting	0°		+/- 20°			

- Allows many applications :
 - Levelling dirt and forest roads,
 - Cleaning of yards, loose stalls and roads,
 - Backfilling ditches and drainage trenches,
 - Ditch creation and cleaning,
 - Earthworks and levelling,
 - Snow removal.
- Upgradeable range with numerous options.
- Interchangeable wear knife made of special steel.
- More movements : tilting, rotation and offset (no offset and tilting on LIGHT blade) with simple adjustments (no tools required).
- More robustness for intensive work : frame design with rounded, thick beam (on model STANDARD and HEAVY DUTY).

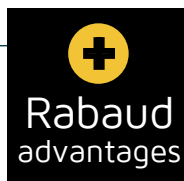

MODELS	Price	Reference	Price	Reference
	LIGHT 1,50 M		LIGHT 2,00 M	
LIGHT BLADE 3-point linkage category 1 and 1N	2530.00	70968A	2735.00	70965A
OPTIONS				
Snow blade	215.00	70970A	215.00	70912A
Depth control wheels - 1 set of 2 (400 x 200 mm)	735.00	70945A	735.00	70945A
Side flaps (1 set of 2)	275.00	70956A	275.00	70956A

MODELS	Price €	Reference	Price €	Reference
	STANDARD 2,00 M		STANDARD 2,50 M	
STANDARD BLADE 3-point linkage category 1 & 2	4565.00	70929A	4890.00	70938A
OPTIONS				
Hydraulic offset (+/- 29°)	960.00	70959A	960.00	70959A
Hydraulic tilting (+/- 20°)	960.00	70955A	960.00	70955A
Hydraulic rotation (34° right / 41° left)	1195.00	70908A	1195.00	70908A
Hydraulic valve dual-acting with support, hydraulic hoses	1-way valve dual-acting	565.00	70939A	565.00
	2-way valve dual-acting	705.00	70940A	705.00
	3-way valve dual-acting	870.00	70941A	870.00
Extension 25 cm	Right	525.00	70906A	525.00
	Left	525.00	70918A	525.00
Side flaps 1 set of 2 - Compatible with extensions	355.00	70914A	355.00	70914A
Depth control wheels - 1 set of 2 (400 x 200 mm)	735.00	70945A	735.00	70945A
Snow blade	L = 2,00 m	355.00	70934A	-
	L = 2,50 m	420.00	70913A	420.00
	L = 3,00 m	-	-	475.00

MODELS	Price	Reference	Price	Reference
	BULL 2,00 M		BULL 2,50 M	
BULL BLADE (Without coupling)	4100.00	70953A	4330.00	70954A
COUPLING HITCH > OBLIGATORY TO DETERMINE				
• 3-point front linkage	1435.00	70960A	1425.00	70960A
• Farm loader, telehandler, backhoe loader, loader, compact loader	935.00	76136F	935.00	76136F
• Forklift elevator	485.00	72505A	485.00	72505A
OPTIONS				
Hydraulic tilting (+/- 20°)	960.00	70955A	960.00	70955A
Hydraulic rotation (34° right / 41° left)	1195.00	70908A	1195.00	70908A
Extension 25 cm	Right	525.00	70906A	525.00
	Left	525.00	70918A	525.00
Side flaps 1 set of 2 - Compatible with extensions	355.00	70914A	355.00	70914A
Depth control wheels - 1 set of 2 (400 x 200 mm)	735.00	70945A	735.00	70945A
Snow blade	L = 2,00 m	345.00	70934A	-
	L = 2,50 m	420.00	70913A	420.00
	L = 3,00 m	-	-	495.00
Safety valve on cylinder for open centre circuit (Merlot, Bobcat, Fdi-sambron, Kubota skidsteer...)	255.00	70993A	255.00	70993A

MODEL	Price €	Reference
FORKLIFT BLADE SPECIAL FOR SNOW With fork holder adapter	2005.00	70958A





HEAVY DUTY 2,50 m



HEAVY DUTY 2,50 m



HEAVY DUTY 2,50 m



Rabaud advantages

- Allows many applications :
 - Levelling dirt and forest roads,
 - Cleaning of yards, loose stalls and roads,
 - Backfilling ditches and drainage trenches,
 - Ditch creation and cleaning,
 - Earthworks and levelling,
 - Snow removal.
- 3 mechanical movements as standard (rotation, offset and tilt). Hydraulic movements available as an option.
- Floating position at inclination to follow the road.
- Upgradeable range with numerous options.
- Interchangeable wear knife made of special steel.
- More robustness for intensive work : frame design with rounded, thick beam (on model STANDARD and HEAVY DUTY).

Technical characteristics

MODELS	HEAVY DUTY 2,00 m	HEAVY DUTY 2,50 m
Coupling	3-point cat. N°2 and N°3	
Blade width	2,00 m	2,50 m
Tractor power	90 up to 150 HP	
Total weight (without option)	650 kg	765 kg
Height	0,60 m	
Ø swivelling axle	100 mm	
Blade rotation	+/- 45° (mechanical) / 20° right and 28° left (hydraulic) Possibility to turn it around	
Offset	+/- 30° (mechanical) / 33° right and 28° left (hydraulic)	
Tilting	20° (mechanical) / 20° (hydraulic)	



Standard equipment

- Interchangeable wear blades in special steel.
- Mechanical rotation +/-45° (it can be turned around).
- Mechanical offset +/- 30°.
- Mechanical tilting 20°.
- Robust frame for high-power tractors.
- 3-point linkage.
- Stands for storage.

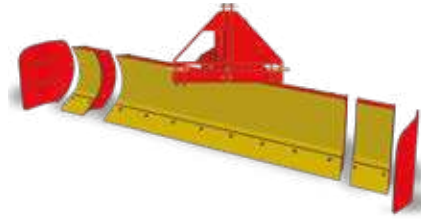

Options : side flaps and/or 25 cm extensions left / right



Options : depth control wheels (a pair) and/or hydraulic wheels on heavy duty blade.

		Price	Reference	Price	Reference
MODELS		HEAVY DUTY 2,00 M		HEAVY DUTY 2,50 M	
HEAVY DUTY BLADE					
3 serial movements : offset, rotation, tilting 3-point linkage		6430.00	70943A	6685.00	70944A
OPTIONS					
Hydraulic rotation without valve		910.00	70930A	910.00	70930A
Hydraulic offset without valve		735.00	70931A	735.00	70931A
Hydraulic tilting without valve		735.00	70936A	735.00	70936A
Extension of 25 cm long (right or left) - the unit		485.00	70967A	485.00	70967A
Hydraulic valve dual-acting with support, hydraulic hoses	1-way valve dual-acting	565.00	70939A	565.00	70939A
	2-way valve dual-acting	705.00	70940A	705.00	70940A
	3-way valve dual-acting	870.00	70941A	870.00	70941A
	4-way valve dual-acting	960.00	70963A	960.00	70963A
	5-way valve dual-acting	1075.00	70992A	1075.00	70992A
Electro-hydraulic valve with handles - 3-way valve dual-acting		2545.00	70961A	2545.00	70961A
Side flaps 1 set of 2 - Compatible with extensions		330.00	70915A	330.00	70915A
Depth control wheels - 1 set of 2	400 x 200 mm	735.00	70945A	735.00	70945A
	600 x 200 mm - WARNING not suitable on 2,00 M BLADE if cylinder for tilting and front mounting	1645.00	70911A	1645.00	70911A
	600 x 200 mm hydraulics WARNING not suitable on 2,00 m BLADE if cylinder for tilting and front mounting - 2 dual-acting necessary	3140.00	70962A	3140.00	70962A
Snow blade	L = 2,00 m	340.00	70950A	-	-
	L = 2,50 m	420.00	70916A	420.00	70916A
	L = 3,00 m	-	-	490.00	70925A

3 MOVEMENTS OF GRADER BLADES



Rotation

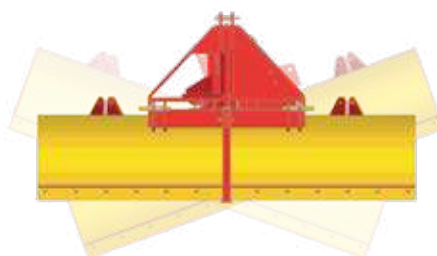

Tilting



Offset

1- GENERAL CLAUSE

Every order (including sale -maintenance - and all kind of services) placed to RABAUD means that you - the customer - accepts these general sales conditions and refuses your own. These general sales Conditions cannot be modified by any stipulation made in all the customer's documents. These general sales Conditions do not exclude the application of special RABAUD conditions - in order to modify or complete these conditions.

The special conditions can be an offer - a price offer or a RABAUD order form.

2- CONTRACT FORMATION

No order will be taken into account and no contract definitively formed - if this order does not come with a dated and established order made on a RABAUD order form or on headed notepaper - signed and stamped by the customer. All the risks related to sold products are transferred to the customer when the contract is formed - following the N°1583 French civil code article.

3- DELIVERY AND TRANSPORT

RABAUD products are deemed to have been delivered as soon as they are made available to the customer.

Each order form specifies whether the goods will be delivered to the customer's premises or to RABAUD's warehouses.

The goods are transported at the recipient's risk.

Delivery times are established based on the information provided to RABAUD on the day of the order.

Unless expressly agreed otherwise, RABAUD is automatically released from any commitment relating to delivery times, which are given for information purposes only.

In the event of delivery by making the equipment available at the RABAUD warehouses, the collection of the equipment shall be at the customer's expense.

Each delivery is accompanied by a delivery note detailing the products delivered.

The Customer is required to communicate a delivery date or to collect the goods within a maximum of 15 days from the notification of availability by RABAUD.

- If delivery or collection does not take place within this period, RABAUD reserves the right to charge the Customer storage costs corresponding to 2% of the pre-tax amount of the order per week of delay, with a minimum flat rate of €250 per week.

- These costs are invoiced as penalties payable by the Customer. The equipment remains the responsibility of the Customer in accordance with Article 2 relating to the transfer of risks.

- After a period of 60 days, RABAUD may automatically terminate the sale, with any sums already paid being retained as a lump sum compensation.

4- CONFORMITY

In case of a delivery at his point of delivery - the customer has to make his reservations. These reservations have to be written on the delivery note. Any later request will not be taken into account. The delivery is considered done and exact with a signature and without reservations on the delivery note. In case of a collection by the customer at RABAUD's Warehouses - the delivery is considered done and exact with a signature and without reservations on the delivery note.

5- PRICE

Unless a contrary agreement - all prices are given as an indication and can be modified any time - without notification. All prices are in Euros and without Taxes. Taxes are invoiced at the rate in force at the day of delivery.

Unless an express agreement - invoices are paid in cash at the delivery. Without a formal notice to the debtor - the failure to pay a bill :

- Lead to the forfeiture of the deadline and means that the customer must pay the whole price immediately.

- Means that RABAUD can stop all other orders - notwithstanding all damages.

- Means that the customer automatically owes a basic penalty for delay - equal to the interest rate applied by the European Central Bank to its most recent refinancing operation - raised by 10%.

- Means that the customer automatically owes a contractual penalty - whose amount is 15% of the inclusive of tax amount of the debt. This is if RABAUD has to institute legal proceedings.

In case of nonpayment of any bill - every further payment - no matter what caused it - will be immediately and in priority charged on the oldest debt.

6- RETENTION OF TITLE CLAUSE

The title transfer for sold goods is subject to the customer's payment at maturity. RABAUD owns the title property of the goods until the payment of the whole price - principal and accessories.

The nonpayment of one bill at its date of payment means that RABAUD could claim the goods. Without prejudice to the previous statements - Risks are transferred to the customer when the contract is formed.

7- WARRANTY

RABAUD and the customer are known each other as professionals for the sold goods.

7-1 Warranty extension

RABAUD products are guaranteed against all functioning defect coming from a matter defect - in the conditions below.

Warranty is strictly limited to the replacement of spare parts - recognized as defective by RABAUD.

The delivery to a RABAUD retailer does not extend warranty: RABAUD products are guaranteed for a year from the delivery date to the final customer.

The delivery date to the final customer is the date written on the invoice sent to the final customer - and on warranty form sent by the final customer to RABAUD.

7-2 Warranty exception

Warranty is excluded :

- When the customer does not pay the price at the deadline

- For pneumatics - belts - equipment and electrical cables - pipes and all other parts that can be damaged.

- For every modification done by someone without RABAUD agreement.

- If the defective matter was brought by the customer

- If the customer refuses that RABAUD makes all investigations on the spare part which is necessary to identify the defect's cause.

- If the functioning defect comes from an intervention on the product - done without RABAUD agreement. Using spare parts which are have not been on the machine at its production make the customer lose his right to guarantee.

- If the defect comes from a standardal wearing of the good - a customer's act of carelessness or a maintenance defect.

- If the functioning defect is a result of an act of God.

- If the delivery date written on the warranty form is different from the date written on the final customer's invoice.

7-3 Warranty conditions

If the customer wants to benefit from warranty - he has to warn RABAUD regarding all defects - without delay and by written means.

This request has to be sent to RABAUD - be done in the 12 months following the order - and be sent with the defective spare part. The number of the machine and the commissioning date must be indicated with your request.

All the costs due to warranty use - such as delivery costs - labour costs (assembling and dismantling) - and immobilization costs are at the customer's expenses.

The replacement of spare parts does not extend warranty time - as it is mentioned in 7-1 article.

7-4 Spare parts delivered to RABAUD

RABAUD will request the customer's written agreement if it needs to physically modify the spare part in order to find the cause of its defect.

If the customer keeps silent during 8 days - it will mean that he accepts the right for RABAUD to search and do all handlings on the spare part.

No compensation of any kind will be owed by RABAUD if the warranty is finally refused - even if the spare part handled with the customer's agreement would be damaged.

When the warranty is used - RABAUD will become the owner of the replaced spare part - when the customer receives the new part from RABAUD.

After a close inspection of the so called defective spare part - and if the right to warranty is refused - RABAUD can destroy this spare part - 1 month after having told the customer to take it back by a registered letter with confirmation of receipt - and if the customer keeps silent.

8- OUT OF WARRANTY INTERVENTIONS

Out of warranty interventions and replacements of parts done by RABAUD will be the subject of an offer.

9- SPARE PARTS ORDER

The order of spare parts and/or accessories done with machines order at the same moment will give a "machine discount" to the customer. Every order of spare parts and/or accessories further to machines order will only give a "spare parts discount" - except for the "machine discount" rates. For every order of spare parts and/or accessories done further to machines order - the customer must give the type and the serial number of the good - as it is mentioned on the builder plate and the commissioning certificate.

10- RESEARCHES AND PROJECTS

Researches - plans - schemes - drawings - projects and commercial documents of all kind - (especially pricelists and technical instructions) - given or sent by RABAUD always remain under RABAUD's title.

These documents cannot be communicated or used without a written agreement of RABAUD.

11- TERMINATION CLAUSE

If the customer does not execute his contractual obligations - the contract will come to its termination - without a formal notice and for the benefit of RABAUD - without prejudice of damages that could be claimed to the defaulter side.

12- LAW (ELECTIO JURIS) AND JURISDICTION CLAUSE

Only French law applies to all RABAUD contracts. Every litigation will be under the competence of LA ROCHE SUR YON trade tribunal - even in case of appeal or many defendants.

Price list N°2654 substitutes price list N°2553 from 1st February 2026.

